

Defense Personal Property Program Domestic 400NG Tariff – 2024



Personal Property Publication

**Rules Governing the Interstate and Intrastate Movement of
Personal Property for Department of Defense and the Coast Guard**

Managed By:

**United States Transportation Command
Defense Personal Property Management Office (DPMO)**

**508 Scott Drive
Scott AFB, IL 62225**

Effective 15 May 2024 through 14 May 2025

Table of Contents

List of Changes	8
Acronyms	9
Definitions	11
Introduction	13
Purpose	13
Authority	13
Safeguarding Personally Identifiable Information (PII)	13
Presidential Executive Orders.....	14
Operating Authority.....	14
Altering Government Documents	14
Transportation Charges	14
Application of Additional Services	15
Pass Through Requirements	15
Limitation of Action	16
Regionalization	17
Section 1: Rules and Regulations	18
Item 1 - Application of Tariff/Applicable Rate	18
Item 2 - Claims and Liability.....	18
Item 3 - Reserved for Future Use	18
Item 4 - Reweigh, Weighing, and Weights	19
Item 5 - 6 - Reserved for Future Use	23
Item 7 - DoD Approved TSP and TSP Representation	23
Item 8 - Acceptance of Rates: Options to Extend or Modify	24
Item 9 - Routing and Joint Rates	25
Item 10 - Release of Rate Data	25
Item 11 - Reserved for Future Use.....	25
Item 12 - Cancellation of Tariff Pages, Items, or Portions Thereof	25
Item 13 - Reserved for Future Use.....	25
Item 14 - Inspection of Articles.....	25
Item 15 - Reserved for Future Use.....	25
Item 16 - Fuel Policy.....	25
Item 17 - Storage-in-Transit (SIT).....	26
Item 17-1 - Attempted Delivery to Residence from SIT	30
Item 17-2 - Termination of Liability for Goods in SIT	31
Item 18 - Governing Publications	32

Item 19 - Performance and Data Periods.....	33
Item 20 - 21 - Reserved for Future Use	33
Item 22 - Hourly Rates.....	33
Item 23 - 24 - Reserved for Future Use	33
Item 25 - Minimum Charge	33
Item 26 - Reserved for Future Use.....	34
Item 27 - Warehouse Pickup and Delivery Service	34
Item 28 - Stop offs, Diversions, Extra Pickups, and Extra Delivery	35
Item 29 - Tender of Delivery for all Domestic shipments	37
Item 30 - 31 - Reserved for Future Use	37
Item 32 - Prohibited and Restricted Articles	37
Item 33 - Impractical Operations.....	38
Item 34 - Reserved for Future Use.....	38
Item 35 - Third Party Service Charges.....	38
Item 36 - 39 - Reserved for Future Use	40
Item 40 - General Price Adjustment (GPA)	40
Item 41 - Economic Price Adjustment.....	41
Item 42 - 43 - Reserved for Future Use	41
Item 44 - Holidays.....	41
Item 45 - Reserved for Future Use.....	42
Item 46 - Collection of Freight Charges on HHGs Shipments Involving Loss or Destruction In- Transit	42
Item 47 - Offset Action Against Transportation Service Providers (TSPs).....	42
Item 48 - 49 - Reserved for Future Use	42
Item 50 - Effective Date Governing Application of Rules, Rates, and Charges of this Tariff ...	42
Item 51 - 55 - Reserved for Future Use	42
Item 56 - Rates Based On Minimum Weight or Minimum Volume.....	43
Item 57 - Reserved for Future Use.....	43
Item 58 - Removal or Placement of Property from or to Inaccessible Locations.....	43
Item 59 - 99 - Reserved for Future Use	43
Item 100 - Classification of Articles (Commodity Description)	43
Section 2: Additional Services	44
Item 101 - 104 - Reserved for Future Use.....	44
Item 105 - Packing and Unpacking Services.....	44
Item 106 - 119 - Reserved for Future Use.....	49
Item 120 - Extra Labor, Special Services, and Waiting Time	49
Item 121 - 124 - Reserved for Future Use.....	52

Item 125 - Shuttle Service	52
Item 126 - 129 - Reserved for Future Use.....	54
Item 130 - Light and/or Bulky Article Classifications.....	54
Item 131 - 134 - Reserved for Future Use.....	55
Item 135 - Origin and Destination Service Charge.....	55
Item 136 - 174 - Reserved for Future Use.....	56
Item 175 - Overtime Loading and Unloading Service.....	56
Item 176 - 184 - Reserved for Future Use.....	57
Item 185 - SIT Charges	57
Item 186 - 209 - Reserved for Future Use.....	57
Item 210 - Pickup and Delivery Transportation Charges on SIT Shipments.....	57
Item 211 - 224 - Reserved for Future Use.....	59
Item 225 - Pickup and Delivery at Third Party / Self-Storage Warehouses.....	60
Item 226 - Miscellaneous.....	60
Item 227 - Alaska and Intra-Alaska Shipments	61
Item 228 – Special Solicitation (SS) Purpose.....	61
Item 229 – Standards	61
Item 230 - Estimated Traffic/Shipments	62
Item 231 - General.....	62
Item 232 - Participation and Performance.....	62
Item 233 – 299 Reserved for Future Use.....	62
Section 3: One Time Only (OTO) (Boats and Mobile Homes).....	63
Item 300 - Purpose.....	63
Item 301 - Criteria for Use of BOTO/MOTO Rates.....	63
Item 302 - Procedures	64
Item 303 - Submission of Rates and Charges.....	64
Item 304 - Terms and Conditions for TSPs Submission.....	66
Item 305 - Effective Period for Accepted Bid Procedures Are Applicable for Rates.....	66
Item 306 - 314 - Reserved for Future Use.....	66
Item 315 - Origin and Destination Services.....	66
Item 316 - 327 - Reserved for Future Use.....	66
Item 328 - Third Party Service	66
Item 329 - Tire/Tube Repairs or Replacements In-Transit	67
Item 330 - Tow-Away Boat Service (COS B)	67
Item 331 - Haul-Away Boat Service (COS H).....	67
Item 332 - 399 - Reserved for Future Use.....	67

Section 3A: Included Accessorial Services	67
Item 400 - Anti-Sway Devices.....	67
Item 401 - Escort Service	67
Item 402 - Installation of Temporary Lights	67
Item 403 - Tolls and Fees	67
Item 404 - Transit Axles Request.....	67
Item 405 - Inventorying	68
Section 3B: Frequently Requested Accessorial Services.....	68
Item 406A - Packing and Related Servicing Requirements.....	68
Item 406B - Unpacking and Related Servicing Requirements.....	68
Item 407 - Appliance Servicing	68
Item 408 - Preparation of Mobile Home for Movement.....	68
Item 409A - Hitch Installation.....	68
Item 409B - Hitch Removal.....	68
Item 410A - Unblocking	68
Item 410B - Blocking	68
Item 411A – Un-anchoring.....	68
Item 411B - Anchoring.....	69
Item 412A - Removal of Skirting	69
Item 412B - Installation of Skirting	69
Item 413A - Expando, Tipout, or Slideout Removal	69
Item 413B - Installation of Expando, Tipout, or Slideout.....	69
Item 414A - Double-Wide Separation and Preparation for Movement.....	69
Item 414B - Reassembly of Double-Wide	69
Item 415A - Installation of Customer-Owned Axles/Tires	69
Item 415B - Removal of Customer-Owned Axles/Tires.....	69
Section 3C: Specialized Accessorial Services	69
Item 416 - Extra Axles	69
Item 417 - 418 - Reserved for Future Use.....	69
Item 419 - BOTO/MOTO Tire and Tube Repair or Replacement	69
Item 420 - BOTO/MOTO Daily SIT Rate.....	70
Item 421 - 497 - Reserved for Future Use.....	70
Item 498 - Explanation of Abbreviations and Reference Marks.....	70
CONUS Destination Rate Areas (Labeled Regions).....	70
Origin Rate Area Abbreviations for U.S. States.....	70
Item 499 - Surcharges	72

Section 5: Volume Moves (VM).....	73
Item 2000 - Purpose.....	73
Item 2001 - Criteria for Use of VM Rates.....	73
Item 2002 - VM Procedures.....	73
Item 2003 - Submission of Rates and Charges.....	74
Item 2004 - Terms and Conditions for Individual Rate Bid Submission.....	75
Item 2005 - Preparation of Individual Rate Submissions.....	75
Item 2006 - Effective Period for Accepted Bid Submission.....	76
Item 2007 - Receipt of Submission.....	76
Item 2008 - Reserved for Future Use.....	76
Item 2009 - Punitive Action.....	76
Item 2010 - Correction to VM Individual Rate.....	76
Item 2011 - Acceptance/Rejection of Individual Rate Submission.....	77
Item 2012 - VM Rates - Public File.....	77
Item 2013 - Selecting Number One TSP for VM.....	77
Item 2014 - Reserved for Future Use.....	77
Item 2015 - Additional Guidance.....	77
Item 2016 - VM Shipment Distribution.....	78
Item 2017 - 2022 - Reserved for Future Use.....	78
Item 2023 - VM Blackout Status.....	78
Appendix A: Costing a Domestic Shipment.....	79
Baseline Files and “How to”.....	79
A. General Information.....	79
B. Linehaul Charges.....	80
Computing Linehaul Charges (LHS).....	81
Determine the Base Linehaul (BLHS).....	81
Determine the Origin and Destination Linehaul Factors (OLF/DLF).....	81
Determine SH Charge (ONLY applies if shipment moves 800 miles and less).....	82
Determine Linehaul Charge (LHS) TOTAL.....	82
Computing Non-Linehaul Charge.....	82
Item 135A (Origin Service Fee).....	82
Item 135B (Destinations Service Fee).....	82
Item 105A (Full Pack/Unpack).....	82
Item 105B (Crating) and (Uncrating) Regular Crate.....	83
Item 185A (First Day) and Item 185B (Additional Days) SIT.....	83

Item 210A (SIT Pickup/Delivery 30 Miles or Less), Item 210B (SIT Pickup/Delivery 31-50 Miles), Item 210C (SIT Pickup/Delivery Over 50 Miles), and Partial Deliveries out of SIT (less than 1,000 lbs):.....	84
How to Calculate Shipment To/From Alaska.....	85
Shipments To/From Alaska.....	85
Computing Non-Linehaul Charge	86
Item 135A (Origin Service Charge).....	86
Item 135B (Destination Service Charge).....	86
Item 105A (Full Pack/Unpack)	87
Item 105B (Pack Regular Crate) and (Unpack Regular Crate).....	87
Item 185A (SIT 1st Day) and Item 185B (SIT Additional Day).....	87
Item 210A (SIT Pickup/Delivery 30 Miles or Less), Item 210B (SIT Pickup/Delivery 31-50 Miles), and 210F (SIT Pickup/Delivery Over 50 Miles (Alaska))	88
Bunker Surcharge.....	88
.....	90
Figure 1. Certification of Independent Pricing.....	90
Figure 2. Nondisclosure Agreement.....	91
Figure 2. Nondisclosure Agreement (Cont'd)	92
Figure 3. DP3 Regions Map.....	93

List of Changes

Version Number	Description	Revision Date	Page Numbers
400NG 2022	<ul style="list-style-type: none"> - Grammatical changes made throughout document - Updated website URLs and site paths throughout document - Removed references to 105E throughout document - Added GSA, PEO, TRB, and USPS to list of acronyms - Removed Code 2 Selection Criteria language (Moving to DTR Chapter 401) - Removed Lumber Associated Cost Increases language - Removed list of Regionalized GBLOCs - Item 4 – Added and adjusted language - Item 40 – Adjusted language - Item 105 – Added language and replaced reference to Type II container with SDDC approved container - Item 125 – Clarified language - Item 499 – Removed COF and WAR Surcharges - Appendix A – Adjusted language to account for removal of 105E 	05 Nov 2021	<p style="text-align: right;">10 16 16 17 19 39 44, 47 54 70 81</p>
400NG 2022 Change 1	<ul style="list-style-type: none"> - Updated website URLs and site paths through document - Item 4: Removed language regarding payment up to 110% of customers weight entitlement and non-performance fee - Item 105: Updated website location for Weight Estimator - Item 499: Clarified language - 	01 Mar 2022	<p style="text-align: right;">19 46 70</p>
400NG 2022 Change 2	<ul style="list-style-type: none"> - Item 4: Para 11, updated and transferred “TSP must be cognizant of reweigh requests” language to para 3.a.1) 2) 3) a). Para 5 and para 11.b.4), replaced the word “net” with “tare”. Added language regarding weights for gun safes. - Item 210: Updated pre-approval mileage to 100 miles 	03 Jun 2022	<p style="text-align: right;">19, 21- 22 58</p>
400NG 2022 Change 3	<ul style="list-style-type: none"> - Corrected paragraph/numbering through document - Item 4: Para 4., clarified reweigh invoicing procedures language. - Para 5., corrected language by replacing “tare” with “net” - Para 11.b., removed “Code 2” reference and updated language - 	20 Jul 2022	<p style="text-align: right;">19, 22</p>
400NG 2022 Change 4	Item 4: Adjusted reweigh language	18 Oct 2022	<p style="text-align: right;">21-23</p>
400NG 2023	<ul style="list-style-type: none"> - Grammatical changes made throughout document - Acronyms: Added additional acronyms - Item 120: Added verbiage regarding gun safes - Item 19: Updated Data Periods for CSS 	04 Nov 2022	<p style="text-align: right;">10 49-50 34</p>
400NG 2023 Change 1	<ul style="list-style-type: none"> - Item 4: Updated Reweigh language - Item 22: Clarified language - Item 47: Corrected to General Services Administration - Item 185: Para 3., Removed one day storage verbiage and added reference to TOS. 	12 Sep 2023	<p style="text-align: right;">22 33 42 57</p>
400NG 2024	<ul style="list-style-type: none"> - Added Special Solicitation Acronym and Definition - Item 16: Changed the FSC Baseline from \$2.50 to \$3.50 - Item 228 – 232 Added Special Solicitation - Item 498: Added Region 16 (Key West) - Region Map added Region 16 (Key West) 	29 Dec 2023	<p style="text-align: right;">9 & 12 26 61 - 63 71 93</p>

Acronyms

Acronym	Description
BL	Bill of Lading
BPC	Base Point City/Cities
BSC	Bunker Surcharge
CEU	Current Employment/Unemployment Index
CFR	Code of Federal Regulations
CONUS	Continental United States
COS	Code of Service
CPI	Consumer Price Index
CU FT.	Cubic Foot/Cubic Feet
CWT	Hundredweight (TWT / 100)
CWT-M	Hundredweight miles
DoD	Department of Defense
DPS	Defense Personal Property System
DTOD	Defense Table of Official Distances
DTR	Defense Transportation Regulation
FSC	Fuel Surcharge
GBD	Government Business Day(s)
GPA	General Price Adjustment(s)
GSA	General Services Administration
HHGs	Household Goods
ITO	Installation Transportation Officer
LHS	Linehaul Charge
NADA	National Automobile Dealers Association
NTS	Non-Temporary Storage
NTSR	Non-Temporary Storage Release
OBL	Ocean Bill of Lading
OCONUS	Outside the Continental United States
OT	Overtime
OTO	One-Time-Only
PEO	Presidential Executive Order
PBP&E	Professional Books Paper and Equipment
PPSO	Personal Property Shipping Office
RDD	Required Delivery Date
SA	Service Area
SCAC	Standard Carrier Alpha Code
SIT	Storage-in-Transit
SMO	Storage Management Office
SS	Special Solicitation
TO	Transportation Officer; Transportation Office
TPPS	Third Party Payment System
TRB	Transportation Review Board
TSP	Transportation Service Provider
USPS	United States Postal Service
USTRANSCOM	United States Transportation Command

Acronym

WHC

ZIP3

Description

Waterhaul Charge

First three digits of a U.S. postal ZIP code

Definitions

Bill of Lading (BL): An accountable shipping document used for the acquisition of authorized transportation and related services from commercial Transportation Service Providers (TSPs) for the movement of DoD-sponsored personal property shipments.

Channel: A unique combination of three elements - an origin rate area, a destination rate area, and a code of service (COS) - by which Department of Defense (DoD) solicits and TSPs file rates for movement of DoD HHGs.

Code B: Movement of Domestic boat or personal watercraft. (Including but not limited to canoes, kayak, dinghies, row boats, jet skis, skiffs, and skulls) with an associated trailer with the combined single unit dimension is over 14 feet traveling as a One-Time-Only (OTO) "Tow-Away" boat.

Code D: Movement of Domestic HHGs in a motor van or container from origin residence in Continental United States (CONUS) to destination residence in CONUS. The actual mode of service is at the discretion of the TSP. Movement is based on Code "D" rates at no extra cost to the shipper or customer.

Code H: Movement of Domestic boat or personal watercraft. (Including but not limited to canoes, kayak, dinghies, row boats, jet skis, skiffs, and skulls) with or without an associated trailer with the combined single unit dimension is over 14 feet traveling as an OTO "Haul-Away" boat.

Code S: Movement of Domestic mobile home OTO shipment.

Code 2: Movement of Domestic HHGs in a container from origin residence in CONUS to destination residence in CONUS. Use of commercial best practice containers is authorized. Shipments must always be containerized, will never be customer packed, and cannot be left unsecured or outdoors. Containerization must be completed at customer's residence unless the origin Personal Property Shipping Office (PPSO) authorizes containerization at the TSP/Agent warehouse.

Consignee: The recipient to whom the personal property is addressed or consigned for final delivery.

Consignor: The person or activity that is the supplier or shipper of the product.

Designated Agent: A person that has legal Power of Attorney to make arrangements with the PPSO to ship, monitor Storage-in-Transit (SIT), or receive the customer's property.

Government Business Day(s) (GBD): A business day (i.e., Monday through Friday) that is not a Federal Holiday.

Linehaul Factor (LF): An additional transportation component that consider the varying transportation costs associated with each Service Area (SA). The LF is subject to the linehaul discount and is computed at both origin and destination (blocks 18 and 19 of the BL), which is added to the total linehaul for each shipment.

Notices or Communications: Required notices or communications shall be in the DoD Defense Personal Property System (DPS) whenever possible. Otherwise, when such

communications are required to be “in writing,” they may be transmitted by mail, by telephonic facsimile, or by electronic mail.

Owner: Pertains to the person (customer) whose property is being shipped and whose name the property is stored under and shall mean the person who is entitled to a shipment at DoD expense, even if that person does not have formal legal title to all of the goods that are shipped, and shall include the owner’s agent/consignee, or, in the case of a deceased owner, the survivors or estate of the owner. The term “Owner” is interchangeable with “customer.”

Shipper: Is technically the party that contracts with the TSP and pays for the shipment. In DPS, the shipper is usually the Government except for Self-Procured moves.

Shorthaul (SH): An additional linehaul component for shipments moving 800 miles or less (via all modes combined). SH distance is computed by determining the mileage between the requested pickup (block 19 of the BL) and the requested delivery address (block 18 of the BL) at the time the shipment is offered and accepted by the TSP and is measured as hundred weight-miles (cwt-m). Determine cwt-m by multiplying total shipment miles multiplied by hundredweight (cwt).

**Exclusions apply such as changes prior to pick-up and diversions. References made to blocks 18 & 19 in the BL will be reflected in the DPS BL at the completion of the pre-move survey.*

Special Solicitation (SS): Rates solicited by USTRANSCOM from individual TSPs for movement of personal property between specific rate areas. (see Items 228 – 232)

Subcontract: Any contract entered into by a subcontractor to furnish supplies or services for performance of a prime TSP under this tender or a subcontract.

Subcontractor: Any supplier, distributor, vendor, or firm that furnished supplies or services to or for a prime TSP or another subcontractor.

TSP: Any party, person, or carrier that provides freight/personal property transportation and related services to an agency, including Motor Carrier and Freight Forwarder. A DoD approved TSP is a TSP meeting USTRANSCOM requirements who has received a notice of acceptance into the DoD Personal Property Program (DP3). A TSP must have approval before filing rates.

Waterhaul: An additional weight-based transportation component that considers the varying transportation costs associated with shipments to/from Alaska via motor-water-motor mode (does not apply to Intra-Alaska).

Introduction

Purpose

1. The 400NG Tariff serves as the principal DoD Domestic Tariff that governs the transportation of Household Goods (HHGs), personal effects, property, and other similarly defined articles in all points of the United States (U.S.) and District of Columbia (DC) with the exception of Hawaii.
2. This Tariff was developed by United States Transportation Command (USTRANSCOM) as part of the Defense Personal Property Program (DP3), in partnership with all the military services and commercial industry associations.
3. This Tariff uses Base Point Cities (BPCs) and Rand McNally Mileage to rate shipments. Data from the National ZIP Code Directory (NZCD) was used to establish the BPCs and data from Rand McNally Mileage Guide 19 (MG 19) establishes the mileage between the BPCs. There are currently 783 BPCs. When a shipment moves within the same BPC, Defense Table of Official Distances (DTOD) shall be used to determine the mileage.
4. USTRANSCOM does not endorse any third-party software or products that utilize these files to compute shipment costs and any discrepancy between such software and these posted rates is no fault of USTRANSCOM. Only rates provided by USTRANSCOM will be the final authority for payment.

Authority

Under responsibilities assigned to the Commander, United States Transportation Command as stated in the Defense Transportation Regulation (DTR) 4500.9-R. USTRANSCOM is responsible for the negotiation of rates for shipment of Domestic HHGs. The rates are solicited on behalf of the entire DoD, including civilian appropriated and non-appropriated fund employees, and the U.S. Coast Guard (USCG).

Safeguarding Personally Identifiable Information (PII)

1. All entities entering into contracts with the Federal Government are expected to protect their IT Systems. There are two basic types of protection contractors are expected to apply to their IT systems for unclassified information, (a) "Basic" and (b) Controlled Unclassified Information (CUI). (FAR 52.204-21, https://www.acquisition.gov/far/part-52#far_52_204_21)
 - a. Basic. All contractors are expected to maintain this level of security. This includes the typical controls any commercial entity would employ to protect their information and are enumerated in FAR 52.204-21(b)(1)(i)-(xv). This includes controls like escorting visitors, sanitizing storage discs before disposing, and changing passwords.
 - b. CUI. Contractor's packing, loading, transporting, or stowing HHGs are exposed to DoD personnel's personally identifiable information (PII) in the performance of their contract. In addition to customer's current personal address, phone number and often e-mail, TSPs also have access to customer's new location as well as their Social Security Number. This PII is stored and used by every company in the HHGs program and must receive the commensurate level of protection from those entities. Consequently, in addition to the basic protection, contractors that manage PII in their own or purchased environment(s) require additional security controls as outlined in NIST SP 800-60. This

ensures contractors maintain adequate security (DFARS 252.204-7012 (b)) and comply with Cyber incident reporting requirements (DFARS 252.204-7012 (b)) should a breach occur. (<https://www.acquisition.gov/dfars/part-252-solicitation-provisions-and-contract-clauses#DFARS-252.204-7012>)

- c. Contractors who subcontract portions of their work are required to include the substance of this paragraph in their agreements.

Presidential Executive Orders

TSPs are responsible for adhering to all Presidential Executive Orders (PEOs). These requirements apply to all TSPs regardless of mode. Failure to comply with PEOs may result in punitive actions.

Operating Authority

1. By submitting individual rate records/tenders, the TSP represents to the Government that service shall be performed in accordance with the rules and regulations of this Tariff and the Tender of Service (TOS), as amended or superseded.
2. The TSP also acknowledges possession of the required operating authority to transport HHGs from, to, or between the places set forth in the TSP's individual rate records/tenders.
3. USTRANSCOM reserves the right to place in non-use or revoke any TSP found to have filed rates in a location in which they do not possess authority and/or USTRANSCOM approval. Contact USTRANSCOM Quality Support Team for questions concerning operating authority.

Altering Government Documents

When issued a BL, the TSP/Agent will not redact, modify, or remove any information on the BL issued to move DoD HHG/UB. The government is the only authorized agency who can redact, modify, or remove information on the BL through an SF1200.

Transportation Charges

1. Transportation charges in this Tariff
 - a. include shipment loading at the point of origin, vehicle transportation to point of destination, and shipment unloading at destination,
 - b. apply based on the actual weight of the shipment, subject to the minimum weights provided in the rules of this Tariff,
 - c. do not include the Additional Services listed in Sections 1 and 2 of this Tariff, and
 - d. are subject to the Linehaul discount.
2. Transportation charges apply for the transportation of HHGs between all points in the U.S. and the DC (except Hawaii).
 - a. Charges apply between BPCs (the MG 19 distance is used to determine the applicable charges in Alaska). If the United States Postal Service (USPS) changes the BPC of a ZIP code after the effective date of this Tariff,
 - 1) the old BPC shall be used for rating purposes until a new corresponding BPC is incorporated into a revised edition, or
 - 2) a modification to this Tariff, including the electronic rating engine portion.

- b. To simplify the application of charges, 400NG Tariff incorporates many of the commonly applied individual additional service charges into a single Origin/Destination Service Fee that applies along with the transportation charges.
- c. Peak Season charges apply on shipments requested pick up date of May 15th through September 30th of each calendar year at the time the shipment is offered and accepted by the TSP.
- d. There are 7 BPCs in Alaska, when delivering a shipment to/from an Alaskan BPC over a distance of more than 14 miles, use Section 7 of the 400NG Baseline Rates to determine the Intra-AK base LHS. Charges for shipments 14 miles or less are part of the waterhaul rate.
 - 1) Shipments to/from Alaska must utilize the nearest BPC to the requested pickup address (block 19 of the BL) and/or the requested delivery address (block 18 of the BL) at the time the shipment is offered and accepted by the TSP. Use of Kodiak BPC is limited to shipments to/from the island of Kodiak and the immediate surrounding islands (not including any part of the Alaskan mainland).
 - 2) When only 1 BPC (with the associated ZIP3) is on the same land mass, that BPC must be utilized (i.e., the BPCs for Homer is Anchorage and Kodiak; since the shipment is on the same land mass as Anchorage, the BPC utilized is Anchorage).
3. The transportation and storage discounts that apply are based on the requested pickup date at the time the shipment is offered and accepted by the TSP. If a TSP negotiates a change in pickup date with the customer or delivers a shipment from SIT the prevailing applicable rate (dLHS and dSIT) will remain the rate in effect on the original requested pickup date at the time the shipment is offered and accepted by the TSP (see Item 1).
4. Except for pickup or delivery of SIT shipments transported under Item 210, the linehaul transportation charges on ALL FIRST PROVISIO shipments picked up for delivery to SIT or delivered from SIT during the period of May 15th through September 30th of each calendar year will be subject to the peak season transportation charges provided in this Tariff.
5. The Transportation Charges apply for shipments of HHGs consisting entirely of articles embraced in paragraph 1 of Item 100.

Application of Additional Services

Except as may otherwise be specifically provided for, the Additional Service rates and charges provided for in this section apply throughout the U.S. and are in addition to all other rates in this Tariff.

Pass Through Requirements

1. In circumstances where a TSP elects to subcontract for any portion of HHGs movement by truck, the TSP shall be required to pass through any charges paid by the Government to the TSP to the person(s), corporation(s), HHGs carriers, HHGs freight forwarders, or other authorized TSP(s) that bear the cost for any shipment(s), or any portion thereof, transported under this guidance. TSPs shall insert a clause that meets the intent of this requirement in any subcontract with any agent, motor carrier, or HHGs freight forwarder, or other person or entity at any tier authorized to transport HHGs shipments.

2. For the convenience of TSPs, a sample provision implementing this requirement is provided herein as follows:
 - a. TSP agrees that it shall be solely responsible to pass through and pay subcontractor any charges associated with crating, uncrating, shuttle service, additional labor, Florida Keys Service Charge, all SIT related charges (i.e., delivery into origin SIT, delivery out of destination SIT, SIT 1st Day, Warehouse Handling, and Additional Days of Storage), and Fuel Surcharge (FSC) for the relevant portion of these services actually performed by subcontractor for sums actually paid to TSP for DoD HHGs shipment(s) utilizing these services.
 - b. TSP agrees that any crating, uncrating, Shuttle Service, additional labor, Florida Keys Service Charge, all SIT related charges (i.e., delivery into origin SIT, delivery out of destination SIT, SIT 1st Day, Warehouse Handling, and Additional Days of Storage), and/or FSC amount owed to subcontractor shall be paid immediately upon TSP's receipt of payment from DoD.
 - c. TSP and subcontractor agree that in no event shall subcontractor be entitled to file a transportation claim directly with the U.S. Government, or that the subcontractor shall have a cognizable or valid claim directly against the Government due to failure or refusal of a TSP to pay any subcontractor any lawfully owed costs actually incurred by subcontractor."
3. In no event shall this legal requirement be interpreted to provide any subcontractor lacking privity of contract with the U.S. Government with legal standing to assert a transportation claim for payment pursuant to 31 U.S.C. 3726 against USTRANSCOM, or the DoD due to a TSP's failure to insert the required clause in any subcontract, or the failure of a TSP to otherwise properly comply with the FSC pass through requirement established by Section 884 of the 2009 National Defense Authorization Act.
4. TSPs who fail to comply with the requirements of this provision may be subject to punitive action.

Limitation of Action

All claims and actions at law by the issuing TSP for recovery of its charges on shipments subject to the provisions of this Tariff will be filed IAW 49 USC Sec. 14705.

Regionalization

As of 1 January 2019, all planned Regionalization have been completed. Please refer to the current State GBLOC in the PPCIG.

Section 1: Rules and Regulations

Item 1 - Application of Tariff/Applicable Rate

1. Application of Tariff
 - a. This Tariff contains two components:
 - 1) A printed tariff that contains
 - a) the governing rules and regulations and an explanation of the transportation charges and the additional services that apply,
 - b) a printed spreadsheet containing all of the baseline charges comprising this Tariff, and
 - c) an associated mileage calculation tool which can be used to calculate applicable charges.
 - 2) An electronic rating engine programmed into DPS that calculates transportation charges and the rates (discounts) that apply for additional services performed in the U.S. and then computes the cost of moving the shipments.

Note: Refer to Appendix A (Baseline Files and “How to”) to compute or verify the cost submitted by the TSP for a shipment(s).

2. Applicable Rate
 - a. Acceptance and movement of a shipment by the TSP over a traffic channel under a BL shall constitute an agreement by the TSP to perform the transportation services at the original rate filed by the TSP.
 - b. Change in pickup date: If a TSP is offered and accepts a shipment over a traffic channel and later negotiates with the customer a change in the pickup date that crosses into a new annual rate cycle, the TSP will move the shipment at the LH and SIT discounts effective on the original requested pickup date at the time the shipment is offered and accepted by the TSP.
 - c. The TSP will utilize the tables in effect on the originally requested pickup date for all charges except for SIT and Accessorial Services as identified in the Item Code Listing located at <https://www.ustranscom.mil/dp3/pdfs.cfm> which will utilize the tables in effect on the actual pickup date.

Item 2 - Claims and Liability

The Claims and Liability Business Rules are hereby incorporated into this Tariff; by submitting rates, TSPs agree to the Claims and Liability Business Rules, which can be found on the USTRANSCOM website at <https://www.ustranscom.mil/dp3/pdfs.cfm> (Under 2024 Business Rules Section).

Item 3 - Reserved for Future Use

Item 4 - Reweigh, Weighing, and Weights

(4A) - Reweigh (Origin)

(4B) - Reweigh (Destination)

1. TSPs will determine the weight of each shipment transported prior to the assessment of any charges depending on the shipment weight. Except as otherwise provided in this item, the weight shall be obtained on a scale meeting the definition of a certified scale as provided in Code of Federal Regulations (CFR) Title 49, Part 375.103.
2. Reweighs consist of automatic reweighs and requested reweighs. Pre-approvals for requested reweighs will be submitted utilizing item code 4A and 4B. Pre-approvals for automatic reweighs are not required.
3. TSPs must be cognizant of reweigh requests.
 - a. When requested by the PPSO/customer prior to the arrival of the shipment in DPS.
 - 1) TSP must conduct the reweigh before the actual commencement of unloading of the shipment for delivery or placement into storage.
 - 2) Upon request, TSP must provide the customer and the responsible PPSO the time and specific location for each weighing to allow either party the opportunity to witness the reweigh.
 - 3) All DPS reweigh orders (DPS automatic reweigh email, PPSO or Customer request) are valid and should be complied with unless it's a minimum requirement.
 - a) Reweighs on HHG shipments weighing less than 1000 lbs. are not authorized.
4. Invoicing for requested and automatic reweighs
 - a. TSP will submit billing under Item Code 226A (Miscellaneous) with a note stating, "reweigh fee" (discount does not apply).
 - b. Do not bill using Item 4A or Item 4B.
 - c. See the 400NG Baseline Rates for the reweigh charge only (Item 4A/4B) and discount does not apply.
5. Reweigh charge shall be payable for both automatic and requested reweighs ONLY when one of the following apply:
 - a. The reweigh net scale weight is equal to or greater than the initial net scale weight.
 - b. The reweigh net weight is less than initial net weight and within the following tolerances:
 - 1) Shipments weighing 5,000 pounds or less; the initial net scale weight minus reweigh net scale weight is less than 150 pounds; or
 - 2) Shipments weighing more than 5,000 pounds; the initial net scale weight minus reweigh net scale weight is less than 5% of the lower net scale weight.
6. Reweigh charges do not apply on partial deliveries from SIT (see Item 210).
7. Failure to perform a requested or automatic reweigh may result in punitive action (i.e., immediate suspension for non-performance of reweigh).

-
8. Automatic Reweighs (pre-approval not required) – Tolerances as outlined above shall apply. TSPs will be required to automatically reweigh **shipments that meet any of the following criteria**:
- a. All shipments for grades E-6 thru O-10, and DoD Civilians, weighing 7,000 pounds or more.
 - b. All shipments for grades E-1 thru E-5, weighing 4,000 pounds or more.
9. Weighing Procedures:
- a. Except as otherwise provided in this item, the weight of each shipment shall be obtained by determining the difference between the tare weight of the vehicle on which the shipment is to be loaded prior to the loading and the gross weight of the same vehicle after the shipment is loaded; or the gross weight of the vehicle with the shipment loaded and the tare weight of the same vehicle after the shipment is unloaded.
 - b. At the time of both weighings, the vehicle must have installed or loaded all pads, dollies, hand trucks, ramps, and other equipment required in the transportation of such shipments. Neither the driver nor any other persons shall be on the vehicle at the time of either weighing.
 - c. All fuel tank(s) on the vehicle shall be full at the time of each weighing or, in the alternative, no fuel may be added between the two weighings when the tare weighing is the first weighing performed.
 - d. The trailer of a tractor-trailer vehicle combination may be detached from the tractor and the trailer weighed separately at each weighing providing the length of the scale platform is adequate to accommodate and support the entire trailer at one time.
 - e. Containerized shipments (Code 2 and Code D shipments, where the TSPs elects to containerize at no additional cost to the Government), or shipments weighing 1,000 lbs or less may be weighed on a certified platform or warehouse scale prior to loading for transportation or after unloading. The net weight of shipments transported in containers shall be the difference between the tare (empty) weight of the container, including all pads, blocking, and bracing used or to be used in the transportation of the shipment and the gross (full) weight of the container with the shipments loaded therein (CFR Title 49, Part 375.509).
 - f. The shipper or any other person responsible for payment of the freight charges shall have the right to observe all weighings of the shipments.
 - 1) TSPs must advise the shipper, or any other person entitled to observe the weighing of the time and specific location where each weighing will be performed and must give that person a reasonable opportunity to be present to observe the weighing.
 - 2) Waiver by a shipper of the right to observe any weighing or reweighing is permitted and does not affect any rights of the shipper under these regulations or otherwise.
 - g. TSP may substitute manufacturer's weight for automobiles, trucks, vans, motorcycles, campers, and boats in lieu of obtaining separate weight tickets on these articles whenever such articles are included within a shipment. Manufacturer's weight will be obtained from either the

- 1) Branham Automobile Reference Book,
 - 2) National Automobile Dealers Association (NADA) Official Used Car Guide,
 - 3) other appropriate reference sources of manufacturer's weight, or
 - 4) shipper may provide TSP with copies of manufacturer's documents evidencing the weight of the article included in a shipment, unless weighed as part of the gross weight of the shipment.
- h. When Professional Books, Papers, and Equipment (PBP&E) are included as part of the shipment, the weight of such articles will be annotated separately on the BL.
- 1) The weight may be obtained using bathroom or platform-type scales.
 - a) In the event scales are not readily available, a constructive weight of 7 lbs per cubic foot (cu ft.) will be used.
- i. When a gun safe(s) is included as part of the shipment, the weight of such articles will be annotated separately on the inventory next to the line item.
- 1) The weight may be obtained using the manufacturer's weight on the data plate.
 - a) In the event the gun safe(s) do not have a data plate, a constructive weight of 25 lbs. per cubic foot (cu ft.) will be used.
 - b) Small gun safes (drawer safes or similar pistol/handgun safes) without data plates may be weighed using a bathroom or platform scale

10. Weight Tickets:

- a. Per 49 CFR 375.519, TSP must obtain a separate weight ticket for each weighing. The weigh master must sign each weight ticket. Each weight ticket must contain the following six items:
 - 1) The complete name and location of the scale.
 - 2) The date of each weighing.
 - 3) The identification of the weight entries as being tare, gross, and/or net weights.
 - 4) The company or carrier identification of the vehicle.
 - 5) The last name of the individual shipper as it appears on the bill of lading.
 - 6) The carrier's shipment registration or bill of lading number.
- b. When both weighings are performed on the same scale, one weight ticket may be used to record both weighings.
 - 1) Exception: Reweigh weighings cannot be performed on the same scale.
- c. As part of the file on the shipment, TSP must retain the original weight ticket or tickets relating to the determination of the weight of a shipment.
- d. All invoices presented to collect any shipment charges dependent on the weight transported must be accompanied by true copies of all weight tickets obtained in the determination of the shipment weight.

11. Reweigh (Automatic or Required):

- a. Origin Storage in Transit (SIT): If a shipment requires origin SIT, TSP may request SIT and perform the reweigh/witness reweigh at destination (if requested) prior to delivery or placement in SIT at Destination. While in storage, TSP may invoice for all storage cost and SIT additional days in 30-day increments.
- b. Destination SIT: If a shipment requires destination SIT, TSP may request SIT and perform the reweigh/witness reweigh (if requested) prior to delivery or placement into SIT. While in storage, TSP may invoice for all storage cost and SIT additional days in 30-day increments.
- c. Direct Delivery: If a shipment is designated direct delivery, TSP must perform reweigh prior to delivery and cannot invoice for any services until reweigh has been performed and DPS reweigh information updated.
- d. Reweighs will not be performed on the same scale. TSP will be required to invoice on the lesser weight if reweigh falls within the tolerance stated in this section.
- e. TSP will be paid based on either valid weight tickets or a PPSO constructive weight of 7 lbs. per cu ft, whichever is less.

12. TSPs' Reweigh Refund Procedures:

- a. Reweigh refund will apply to all charges. TSP will submit refund(s) to the origin PPSO.
- b. TSP will not be allowed to invoice for destination and/or direct delivery services until:
 - 1) The reweigh has been performed,
 - 2) reweigh information is updated in DPS,
 - 3) and reweigh tickets are provided to the origin PPSO.
- c. If a refund is owed the refund will be submitted on the same invoice with the delivery out of SIT or direct delivery charges, etc.
 - 1) If refund is not submitted on the same invoice, destination PPSO will dispute or deny all destination and/or direct delivery charges until the refund has been submitted and processed for payment.

13. For containerized HHG, TSP may invoice a reweigh using only the "new gross weight" and the "origin tare weight".

- 1) When the reweigh is performed before the shipment is placed into SIT or direct delivers, the TSP must always invoice on the lesser of the two weights.
- 2) To determine whether to approve, dispute, deny, or require the TSP to re-bill services using a lower weight, PPSOs may calculate the new net weight determination as equal to the new gross minus the shipment original tare weight.
- 3) Subsequent completion of the reweigh (new tare weight) must be completed later with applicable follow-on supplemental invoice/reimbursements. If the new tare weight (reweigh tare weight) is:
 - a) Less than the original tare weight, no additional monies are owed as the lower net scale weight will be used for determining applicable charges.

- b) Greater than the original tare weight AND exceeds the tolerance below, the TSP must reimburse the difference using item codes (e.g., LHSREF, Misc. with detailed notes, etc.).
- 4) If the tolerances are not exceeded, then no reimbursement is required.
- 5) Reimbursement to the Government is required if the new tare weight is greater than the original tare weight and if the shipments weigh:
 - a) 5,000 lbs or less; the reweigh tare scale weight minus the initial tare scale weight is more than 150 lbs overall; or
 - b) Over 5,000 lbs; the reweigh tare scale weight minus the initial tare scale weight is 5% or more than the overall lower tare scale weight.

Note 1: For additional reweighing guidance reference DTR Part IV Chapter 402, Appendix B, and Tender of Service (TOS) available at <https://www.ustranscom.mil/dp3/pdfs.cfm>

Note 2: TSP/Agents (origin/destination) must coordinate reweighs and update DPS to mitigate duplication of reweighs (i.e., requested and automatic). To ensure accurate invoicing, if duplicate reweighs occur, TSP must update DPS with the lower of the net scale reweigh weights. The lower of the net scale reweigh weights will also be used to determine if a reweigh charge is applicable.

Item 5 - 6 - Reserved for Future Use

Item 7 - DoD Approved TSP and TSP Representation

TSPs participating in this Tariff must be DoD approved. A list of DoD approved TSPs is available at <https://www.ustranscom.mil/dp3/pdfs.cfm> (Under the Household Goods section).

1. TSPs shall enter the name and phone number for a valid origin representative within DPS at the time of shipment acceptance. TSPs must update this information to reflect the origin representative who will service the shipment prior to performing the pre-move survey.
2. USTRANSCOM procedures governing disqualification and non-use of TSPs, and their affiliates contracted with USTRANSCOM for transportation and/or storage of DoD sponsored personal property will be followed when USTRANSCOM takes action to disqualify or place a TSP in non-use or recommends that such action be taken.
3. This does not apply to contracts entered into pursuant to the Federal Acquisition Regulation (FAR), unless any such contract calls for its application. TRB(s) may consider a TSP's services based on FAR contracts in determining appropriate corrective action, if any.
4. USTRANSCOM may, at its election, continue to honor BL(s), rate tenders, service orders, or similar transportation arrangements that are in existence, at the time the TSP was placed in non-use or disqualified.
5. Any outstanding claims placed against a TSP in non-use or disqualified status, may be transferred by the customer(s) to their Service Claims Office and still be eligible for Full Replacement Value (FRV).

Item 8 - Acceptance of Rates: Options to Extend or Modify

1. To file rates, a TSP must have satisfied all administrative requirements for DoD qualification and possess a current Certificate of Independent Pricing (CIP)/Certificate of Responsibility (COR).
 - a. The TSP must verify that rates filed are the result of independent pricing determinations.
 - 1) This verification includes:
 - a) Completing the CIP/COR in DPS with the understanding that the CIP is agreed to as listed in Figure 1.
 - b) TSPs wishing to utilize an automated data processing (ADP) agent and/or a representative using a DPS Rate Filing User role must ensure:
 - 1 The selected third-party ADP agent and/or a representative using a DPS Rate Filing User role is in compliance with all state and federal antitrust laws.
 - 2 The USTRANSCOM non-disclosure agreement is in place if you are utilizing a third-party ADP agent and/or a representative using a DPS Rate Filing User Role. This completed form must be provided upon request (see Figure 2).
 - 2) The CIP/COR must be resubmitted annually in DPS prior to rate filing.
 - b. Any TSP not filing rates for two consecutive rate cycles may have their market approval revoked, thereby precluding participation in future rate cycles.
2. USTRANSCOM reserves the right to reject any or all offers; to waive informalities in offers received; to negotiate, accept, or reject initial or subsequent submissions without discussion of rates; to nonuse or cancel any rate upon 15 days' notice; and resolicit rates. Acceptance of rates does not result in a requirements contract. Additionally, USTRANSCOM reserves the right, on 15 days' notice, to:
 - a. Extend the effective period of rates by 45 days to modify the rate filing period.
 - b. Change the type of rates being solicited.
 - c. Resolicit rates as a result of Government or TSP actions.
 - d. Take any appropriate action to protect the Government's interests in response to delaying court injunctions, data processing failures, strikes, embargoes, and other policy or economic situations.
3. TSPs are responsible for establishing quality controls and procedures that review their proposed rates prior to actual submission and ensure they have the necessary operating authorities to file those rates.
4. When filing DP3 rates TSPs
 - a. assume any risks associated with cost variables related to any subcontractor or supporting service provider (e.g., claims, invoicing, etc.); DoD will not reimburse or allow "pass through" of any such charges, nor will those charges be considered accessorial costs,

- b. can change their rate(s) as many times as desired prior to the end of each round; the last rate(s) submitted in each round will override all previous rate(s) in the round they were submitted in DPS,
- c. choose to file rates are encouraged to incorporate any potential cost variables into their rate formulation prior to filing their DP3 rates.

Item 9 - Routing and Joint Rates

1. Except as otherwise provided in this Tariff, and subject to any limitation in the scope of operations provisions published for account of individual TSPs, rates apply via all routes made by use of TSP parties to this Tariff, with interchange at common points. For purposes of this rule, a common point is one where the two TSPs interchanging at that point may lawfully serve in the manner required by such interchange.
2. The joint rates published in this Tariff include all charges for drayage or other transfer services at intermediate transfer points on shipments handled through and not stopped for special service at such intermediate transfer points.

Item 10 - Release of Rate Data

Proprietary rate and cost data, submitted by TSPs upon request of USTRANSCOM, is not releasable under the Freedom of Information Act (FOIA).

Item 11 - Reserved for Future Use

Item 12 - Cancellation of Tariff Pages, Items, or Portions Thereof

When this Tariff is amended by any changes the updated Tariff replaces the previous version and becomes the prevailing Tariff on its effective date.

Item 13 - Reserved for Future Use

Item 14 - Inspection of Articles

1. When a TSP or its agent believes it is necessary to inspect the contents of cartons, boxes, etc., they shall make such inspection, cause it to be made, or require other sufficient evidence to determine the condition and contents of the property.
2. TSP will coordinate with the PPSO (e.g., pullback, reschedule) in the following scenarios:
 - a. HHGs, which are determined to be in a condition that makes it liable to impregnate, contaminate, or otherwise cause damage to other HHGs or equipment.
 - b. Articles, which cannot be taken from or delivered to the premises without damage to the articles or the premises.

Item 15 - Reserved for Future Use

Item 16 - Fuel Policy

(16A) - Fuel Surcharge - LHS

(16B) - Fuel Surcharge - DEL to/from SIT

1. The Fuel Surcharge (FSC) applies to commercial TSP Personal Property (PP) movements within the Continental United States (CONUS) and Alaska (excluding mileage traversed through Canada on shipments traveling between Alaska and the Lower 48 states).
 - a. Shipments to/from Alaska are only authorized FSC (Item 16A) if they are picked up/delivered over 14 miles from the nearest BPC water port.
 - b. CONUS shipments to/from Fairbanks BPC are not authorized Linehaul Charge (LHS) from Anchorage to Fairbanks, and TSPs are not authorized Item 16A when the shipment is picked up/delivered 14 miles or less from the Fairbanks BPC.
 - 1) For these shipments, the waterhaul charge (subject to Linehaul discount) includes transportation between Tacoma and the Fairbanks BPC.
2. TSPs must first apply the linehaul or SIT discount to any baseline charges associated with billing item code 16A or 16B.
3. Rates submitted must be all-inclusive. USTRANSCOM will not pay Fuel Related Adjustments (FRA) on
 - a. "Spot bid" or One-Time-Only (OTO) personal property movements; regardless of mode,
 - b. Rail,
 - c. Barge,
 - d. Pipeline, or
 - e. Third party service.
4. USTRANSCOM shall pay the TSP 1% (one percent) of the linehaul rate for every increment of \$.13 (thirteen cents) by which the fuel cost exceeds **\$3.50** at the time of actual pickup.
5. FRA entitlement will be determined by the national average diesel fuel price published on the first Monday of the month (or the first business day after a Monday if the Monday falls on a federal holiday) by the Department of Energy (DOE) and Energy Information Administration (EIA). The diesel fuel prices published by the EIA may be found at:
 - a. EIA Website: <https://www.eia.gov/petroleum/gasdiesel/>
"U.S. On-Highway Diesel Fuel Prices"
 - b. EIA Hotline: (202) 586-6966
6. The USTRANSCOM Personal Property Fuel Surcharge (FSC) Table is available at. <https://www.ustranscom.mil/dp3/pdfs.cfm>

Item 17 - Storage-in-Transit (SIT)

1. Prior to arrival, TSP must provide at least 24-hour notice to the customer before placing shipment in SIT. For further guidance on 24-hour notice see the Tender of Service.
2. SIT of property covered by this Tariff is the holding of the shipment, or portion thereof, (except mobile home and boat shipments) in the warehouse used by the TSP or its agent for storage, pending further transportation, and will be affected only at specific request of the shipper or under the conditions specified below. The TSP may use any DoD-approved SIT facility listed in DPS.

-
- a. All SIT and related charges are based on the requested pickup (block 19 of the BL) and/or the requested delivery address (block 18 of the BL) at the time the shipment is offered and accepted by the TSP.
 - b. For transportation charges on shipments delivering out of SIT beyond 50 miles (Item 210C), the discounts in effect on the requested pickup date when the shipment was awarded will apply.
 3. A shipment or portion thereof may be placed in SIT one or more times for an aggregate period not to exceed 90 days unless the authorized Government representative authorizes additional storage.
 4. When SIT is at origin, charges may be billed after SIT is affected as follows:
 - a. Transportation charges between actual pickup and requested origin (block 19 of BL) at the time the shipment is offered and accepted by the TSP (Item 210A, 0-30 miles will apply).
 - b. Charges for additional services, third party charges and other lawful charges.
 5. When SIT is at other than origin, charges must be billed at the time SIT is affected, as follows:
 - a. Transportation charges between origin (block 19 of BL) and original destination location (block 18 of BL) at the time the shipment is offered and accepted by the TSP, regardless of where the shipment is actually stored.
 - b. Charges for additional services, third party charges and other lawful charges.
 - c. Storage charges may be billed upon
 - 1) expiration of 90 days SIT and any additional 90-day increments,
 - 2) delivery to residence, or
 - 3) conversion to commercial storage.
 6. TSP is responsible to meet customer's expectations for direct deliveries on shipments with delivery addresses entered in DPS at the time the TSP accepted the shipment.
 7. Delivery of shipments to residence from SIT at origin, enroute, or destination will be made on the date requested, if possible. If prior commitments of the TSP prevent delivery on that date, every effort will be made to deliver as soon as possible, subject to the following:
 - a. If the shipment is not removed from storage by the 5th GBD after the requested delivery date(s), storage charges will cease to accrue after such date.
 - b. If the shipment is removed from storage prior to the 5th GBD after the requested delivery date(s), storage charges will cease to accrue the day the shipment is removed.
 8. Transportation charges described below shall apply when the shipment or portion thereof is stored in transit:
 - a. The applicable transportation rate between initial point of pickup and address location shown on the BL (block 18 for destination SIT and block 19 for origin SIT) at the time the shipment is offered and accepted by the TSP, and

-
- b. The applicable transportation rate from the address location shown on the BL (block 18 for destination SIT and block 19 for origin SIT) at the time the shipment is offered and accepted by the TSP to destination point.
9. Split Shipment:
 - a. The transportation charges to apply on a shipment when only a portion of the shipment is stored in transit enroute to destination will be the
 - 1) applicable transportation rate based on total weight of entire shipment, for total distance between pickup and delivery (block 18 for destination SIT and block 19 for origin SIT of the BL) at the time the shipment is offered and accepted by the TSP, plus additional service charges applicable to each portion of the shipment, and
 - 2) total charges for picked up and/or delivered portions shall apply from the point of origin to destination, as those locations are listed in DPS at the time the shipment is offered and accepted by the TSP, regardless of the storage locations.
 - b. On property consigned to SIT where an overflow of property becomes a split shipment delivered to the storage location on different dates, the charges for such property shall be as follows:
 - 1) Transportation charges from initial point of pickup to delivery address (block 18 of the BL at the time the shipment was offered and accepted by the TSP) based on the combined weight of the property stored in transit, and computation of transportation charges will be as provided herein.
 - 2) Storage charges in effect on date of initial pickup will be assessed separately on each portion of shipment stored in transit, except 1,000 lbs minimum weight will apply to the combined weight of property stored in transit. Storage will be rated separately for each portion added, subject to provisions of this Item and Item 185.
 - 3) All subsequent charges will be based on the combined weight of the property stored in transit.
 - c. The transportation charges to apply on a portion of a SIT shipment delivered from storage location to destination will be the applicable transportation rate based on the actual weight of such portion (not subject to minimums), see Item 210. When the portion of a shipment delivering out of SIT is less than 1,000 lbs, TSP should bill the actual weight using Misc. Item code (226A) with detailed notes until further notice. See Appendix A for "actual weight" computation charges.
 10. When the Government provides notice that the destination has changed from the original BL, a correction notice will be provided to the TSP. Destination changes must be recorded on the BL.
 11. When the interstate character of the property is terminated at the storage location before expiration of the time limit specified in Item 17, paragraph 2, transportation, and other lawful charges shall apply per Item 17, paragraph 3 or 4 whichever is applicable.
 12. When HHGs have been placed into SIT at the TSP's or agent's storage location, both the TSP and the warehouseman must have in their possession records showing the following:
 - a. Itemized list of the property with the BL number.

-
- b. Shipment's point of origin and destination.
 - c. Condition of each article when received at and forwarded from the storage location.
 - d. Dates when all charges, advances, or payments were made or received.
 - e. Dates property was delivered to and forwarded from the storage location.
13. Partial withdrawal (delivery) from SIT:
- a. During SIT the shipper or customer may request withdrawal of a portion of the property. The customer must contact the PPSO and the PPSO will arrange with the TSP to schedule a partial delivery out of SIT so that all entitlements can be verified, and pre-approvals entered into DPS for labor, except as provided in the DTR Chapter 402.
 - 1) Inventory item numbers will be furnished by the customer to the TSP/PPSO. PPSO will, in turn, order the service.
 - a) Items for withdrawal should be indicated at the time of packing when possible.
 - b) Only complete cartons or item numbers on the inventory will be withdrawn. Individual cartons will not be opened.
 - 2) When the selection of items requires un-stacking and/or restacking of the shipment or a portion of the shipment, charges for such handling shall be assessed in accordance with Item 120.
 - 3) The customer or Government representative will have the right to be present at the TSP's facility during the sorting of the property. The TSP will deliver, or the customer has the option to pick up the property.
 - 4) TSP is responsible for obtaining actual weight of portion withdrawn.
 - 5) Charges for transportation furnished, if any, for portion selected for delivery shall be assessed on the same basis as would apply to that portion as an individual shipment.
 - b. The following shall be applicable to the portion remaining in storage:
 - 1) Charges for transportation furnished, if any, for the delivery of the remainder of the property shall be assessed on the same basis as would apply to that portion as an individual shipment.
 - 2) Storage charges shall continue to apply on the weight of remainder of the property.
14. During the SIT period, the customer may not add property to that already in SIT.
15. If delivery cannot be made at the address specified on the BL because of impractical operation as defined in Item 33 hereof, or for any other reason other than the fault of the TSP, and neither shipper, consignor, nor customer designates another address at which delivery can be made, TSP will place the property under the SIT provision of this item.
16. When property is placed in SIT, the TSP's limitations on liability also apply to the party in possession of the property.
17. Except as specifically provided for in Item 17, paragraph 8, when property is placed in SIT in segments on different dates:

- a. Transportation rates and additional service charges in effect on the date of placement of the first segment will apply to that segment only.
 - b. Transportation rates and additional service charges in effect on the date(s) that each subsequent segment is placed in SIT will apply to these subsequent segments.
18. When property is removed from SIT and extra pickups are ordered transportation rates and additional service charges in effect on the date of the
- a. extra pickup is performed will apply to the entire weight of the extra pickup, and
 - b. pickup of the SIT portion will apply to the entire weight of that portion.
19. Except as specifically provided for in Item 17, paragraph 8, each portion of the shipment will be rated at the applicable rate in effect on the date of pickup of each portion, based on the total weight of the entire shipment.
20. For all Domestic shipments, SIT does not commence until the TSP's first available delivery date (see Item 29 for further guidance). TSP's first available delivery date and/or first day of SIT cannot be a weekend or U.S. National or officially declared state holiday without pre-approval by the PPSO. Refer to Item 210 for the application of SIT pickup and delivery transportation charges.

Item 17-1 - Attempted Delivery to Residence from SIT

(17A) - Att Del: Less Than 30 Miles

(17B) - Att Del: 31 - 50 Miles

(17C) - Att Del: Over 50 Miles

(17D) - Att Del: 1st Day

(17E) - Att Del: Less Than 30 Miles OT

(17F) - Att Del: 31 - 50 Miles - OT

(17G) - Att Del: Over 50 Miles - Alaska

1. TSP compensation for attempted delivery to residence from SIT when failure to deliver is not the fault of the TSP will be as follows:
 - a. Round Trip: Distance from the storage facility to residence and return: Item 210, Pickup, or Delivery Transportation Charges on SIT Shipments, shall apply. Pursuant to the provisions of Item 210, DTOD shall be used for "key entry mileages" (manual lookup). For example, when a shipment moves within the same BPC.
 - b. SIT: A second first day storage charge will apply when the shipment is returned to SIT at the warehouse location. Storage charges will continue to apply at the additional daily rate until shipment is removed or delivered from storage, except as provided in Item 17, paragraph 6.
 - c. Waiting Time: The provisions of Item 120 will apply if TSP is required to wait at residence. These items require pre-approval from the Government.
 - 1) For Item 17A, use the 400NG Baseline Rates for SIT pickup/delivery under Item 210A; for Item 17E use rates under Item 210D.

- 2) For Item 17C and 17G, use the appropriate linehaul table for computation of baseline charges.
2. Attempted delivery will normally not apply as deliveries are usually arranged directly between the TSP and customer.
 - a. In DP3, the TSP is responsible to maintain contact with the customer.
 - b. Only in circumstances where the delivery date in question was either scheduled by the PPSO or confirmed by the PPSO to be the customer's fault, may the TSP request attempted delivery from the PPSO while at residence.
3. Once the TSP and customer have agreed to a delivery date,
 - a. the TSP MUST update DPS with a "Scheduled delivery date" PRIOR to the actual delivery date or within 2 hours after agreeing to a delivery date/time with the customer, whichever is EARLIER.
 - b. If a TSP fails to enter the scheduled delivery date in DPS the PPSO will have grounds for disapproval of any attempted delivery charge, even if the delivery was scheduled by the PPSO.
4. If a TSP arrives at delivery point and cannot locate the customer or an authorized representative,
 - a. TSP must contact the PPSO while at the delivery point to request pre-approval of an attempted delivery.
 - b. PPSO will have one hour of free waiting time from the time they are contacted to locate the customer/representative or to approve/disapprove the attempted delivery.

Item 17-2 - Termination of Liability for Goods in SIT

1. The TSP shall include the substance of this clause, including the requirement to further flow down the clause, in all subcontracts for/or subcontractors supporting storage under this Tariff. A shipment or portion thereof may be placed in SIT one or more times for an aggregate period not to exceed storage authorized as specified from the PPSO.
2. The TSP's responsibility for a shipment and its liability under the BL for a shipment in SIT shall terminate on midnight of the day specified in the notice which the TSP receives through DPS advising that the shipment will terminate, and the warehouse/subcontractor shall become the final destination of the shipment under that BL.
3. Storage is subject to the Service Members Civil Relief Act, and applicable state, local, and bailment laws and regulations. When the Transportation Officer (TO) determines that the individual DoD customer is no longer entitled to storage of personal property at Government expense and converts the lot in DPS, this will serve as the TSP/warehouse/subcontractor's notice of the determination by the Government and this notification will be provided to the individual DoD customer for their retention as the depositor of the goods in storage.
4. The Government will pay the TSP for all SIT costs, up to and including the day of termination. Once termination has occurred,
 - a. the Government may not revive the TSP's liability under the original BL, or reinstate the original BL.

- b. at the request of the individual DoD Customer, and after all applicable storage charges owed by the individual DoD customer are paid to the warehouseman, final delivery-out services at Government expense may be arranged by the servicing PPSO.
5. The TSP/warehouse/subcontractor shall thereafter recognize the individual DoD customer, not the Government, as the depositor of the property. After the Government determination that the individual DoD customer is no longer entitled to storage at Government expense, the TSP/warehouse/subcontractor acknowledges that any future charges are the sole responsibility of the individual DoD customer.
6. Delivery-out services on shipments converted to customer's expense will be billed at the current 400NG charges minus a 25% discount based on the delivery date of the shipment. When Delivery Out of SIT over 50 miles (Item 210C) is authorized, the current Line Haul (LH) charges minus a 25% discount will be applied for payment of delivery out services.
7. For shipments converted to customer's expense, the TSP shall refund any prepayments due to the nonperformance of the service (i.e., Item 16B, 105A (Unpacking), 135B, etc.) no later than when the TSP invoices for storage charges. When refunding these charges, the TSP shall use the Miscellaneous Item Code (226A) with a detailed note explaining the refund. The appropriate unpacking amount due is IAW the 400NG Baseline Rates.
8. All delivery charges will be paid to the delivering entity on a local voucher submitted to the PPSO.

Item 18 - Governing Publications

1. This tariff is governed by the following described publications:

Title Of Publication	Issuing Agent
DoD Participating TSPs And Scope of Operations and all DoD governing publications are listed in the DTR	USTRANSCOM
National ZIP Code Directory	U.S. Postal Service (USPS)
National 3-digit ZIP Code Directory (See 2 below)	USTRANSCOM
Mileage Guide Number 19 (See 2 - 4 below)	Rand McNally
DTOD will be the governing mileage guide for manual key entry mileages throughout this Tariff	USTRANSCOM

2. The application of this Tariff is governed by the ZIP code for each area or place within the U.S. as assigned by the USPS as found in the NZCD. The first three digits of the ZIP Code define the applicable geographical SA for rate application purposes.
 - a. This Tariff uses a BPC concept. Data from the NZCD is used to establish the BPC and the data from MG 19 establishes the mileage between the BPC. There are currently 783 BPCs and 227 SAs consisting of 20 metro SAs and 207 non-metro SAs. (References to Mileage Guide 19, as well as the other governing publications, also refer to subsequent reissues of these publications.)
 - b. If the USPS changes the BPC of a ZIP code after the effective date of this Tariff, the old BPC shall be used for shipment rating purposes until a new corresponding BPC is provided for herein.
3. The application of specific distance-based items (Item 125, Shuttle Service, Items 17-1, and 210, relating to pickup and delivery transportation charges on SIT shipments [when

destination (block 18 of BL) and residence have the same first three digits in their ZIP codes], and Alaska transportation charges) is also governed by the Mileage Guide as provided herein.

4. Where a mileage radius is named, such mileage radius shall include all points within the described number of highway mileage from the point that designates the mileage basing location of such named city as shown in the governing Mileage Guide. Where cities or points are partly within the described number of miles, such will be considered as wholly within the described number of miles.

Item 19 - Performance and Data Periods

1. The performance periods over which TSPs will be evaluated under this Tariff, and the corresponding Performance Period data cutoffs for calculating Customer Satisfaction Survey (CSS) scores, are as follows:

Performance Periods	Data Periods for CSS
1 January - 14 May	1 February - 31 October
15 May - 31 July	1 April - 31 December
1 August - 30 September	1 September - 31 May
1 October - 31 December	1 November - 31 July

2. Performance scores are calculated and re-ranking of TSPs occurs at the end of each performance period. CSS score used for these performance periods consist of the past nine months of data with the cutoff dates shown above. Ranking is based on a TSP's Best Value Score (BVS) with the Performance Score (PS) calculated per shipment market and the Rate Score (RS) calculated for each channel and COS combination in DPS. See DTR Part IV Chapter 403 for additional details on BVS and how performance periods apply.

Item 20 - 21 - Reserved for Future Use

Item 22 - Hourly Rates

1. Charges based on time shall be computed by multiplying the hourly rate by the time involved.
2. Unless otherwise provided, fractions of an hour will be disposed of as follows:
 - a. Where the time involved is 15 minutes or less, the charge shall be for 1/4 hour.
 - b. When more than 15 minutes but not more than 30 minutes, the charge shall be for 1/2 hour.
 - c. When more than 30 minutes but not more than 45 minutes, the charge shall be for 3/4 hour.
 - d. When more than 45 minutes, but not more than 60 minutes, the charge shall be for 1 hour.

Item 23 - 24 - Reserved for Future Use

Item 25 - Minimum Charge

Except as otherwise specifically provided for in this Tariff, or as amended, shipments transported under the provisions of this Tariff weighing less than 1,000 lbs shall be accepted

only at a weight of 1,000 lbs. Applicable rates and charges based on weight shall be subject to a 1,000 lbs minimum.

Item 26 - Reserved for Future Use

Item 27 - Warehouse Pickup and Delivery Service

1. When a shipment is delivered to or picked up from a warehouse (including third party warehouse and self-storage/mini-warehouse locations), the charges for transportation include only the unloading or loading at door, platform, or other point convenient or accessible to the vehicle.
2. Refer to Item 225, in Section 2, of this Tariff for application of charges to apply when the TSP enters the warehouse (including third party warehouse and self-storage/mini-warehouse locations), at the Government's request, for the purpose of removing items stored from or placing items into the warehouse (including third party warehouse and self-storage/mini-warehouse locations). (Refer to Item 17 for application of SIT charges).
3. When a shipment is delivered to Non-Temporary Storage (NTS) in a government facility, the facility is considered as the final destination. Further movement of the shipment will be made under separate BL/invoice.
4. The Government reserves the right to award the contract for transportation of any lot of personal property stored with a NTS TSP to any TSP the Government may select according to the DTR business rules. The NTS TSP shall promptly, and in accordance with the direction of the appropriate TO, make lots available to the receiving TSP for Carriage on a properly protected loading area of the NTS TSP in a condition satisfactory to be received by such TSP for Carriage. The NTS TSP shall permit any such TSP for Carriage to inventory and load property from its facility without any charge to the receiving TSP for Carriage or additional charge to the Government not already in the NTS tender and will acknowledge the receiving TSP's notation of damage or shortage by signing the receiving TSP's exception sheet or rider, noting the damages and/or shortages, or by allowing the receiving TSP's representative to note damages and/or shortages on the NTS TSP's inventory form. The NTS TSP is obligated to repack, at no cost to the Government, any carton refused by the TSP due to improper packing, which has been verified by the TO, or their representative.

When a shipment pickup address is an NTS facility and the TSP missed the pickup date as a result requiring the NTS TSP to continue storage and liability for the property, the NTS TSP will be compensated for continued storage on the shipment.

- a. Communication: The NTS TSP is not required to stay open after 5 p.m. All services (e.g., rider, inspection, loading, etc.) must be completed before closing, unless otherwise agreed to by the NTS TSP. To best facilitate this, the TSP must coordinate a pickup date and time with the NTS TSP, allowing enough time to perform all services.
- b. Failure by NTS TSP to Prepare Lot: In the event a NTS TSP fails to prepare a lot (either partial or full) for pickup by the TSP on the agreed date, the TO will advise the USTRANSCOM Storage Management Office (SMO). Prior to determining fault or initiating payment, the PPSO/PPPO must contact the SMO. The SMO will make a final determination against the NTS TSP for possible extra charges attributed to the NTS TSP for not preparing storage lot as ordered. If work does not commence within 1 hour of free waiting time the TSP will be paid waiting time (reference Item 120, paragraph 7 and

the 400NG Baseline Rates, Additional Rates tab. Note: to find the correct Service Schedule use the 400NG Rating Tool and enter the Origin ZIP3 in the "Origin ZIP3" block (Cell C7) and the Service Schedule will display in Cell L7). After the PPSO has determined the cost of waiting time, the PPSO will advise the NTS TSP of the refund amount. The NTS TSP will refund the amount stating, "Waiting time for delay in preparing Non-Temporary Storage Release (NTSR) lot."

- c. Missed Pickup by TSP: In the event the TSP does not pick up the lot on the specified date, between the hours of 8 a.m. and 5 p.m., the NTS TSP shall notify the TO and continue to store, protect and be responsible for the property. If NTS TSPs do not re-handle the property, or if it is determined that the property did or could remain staged, they should not be compensated for re-handling. The TO should coordinate with the SMO if they have questions about re-handling. Appropriate compensation will be made for putting the shipment back into storage, upon approval of the TO. The DD Form 1164 will be amended and/or reissued to authorize the additional cost and document the TSP failure as the cause of the additional cost. Further, the PPSO will initiate set-off action against the TSP on the applicable BL through DPS for additional charges (i.e., handling in, etc.) attributed to the TSP for not picking up the storage lot as scheduled. After the PPSO has received the cost for re-handling from the NTS TSP, the PPSO will advise the TSP of the refund amount. The TSP will refund the amount in DPS on the same invoice they submit for origin services using the Item Code 226A with a note stating, "NTSR missed PU refund fees".

Item 28 - Stop offs, Diversions, Extra Pickups, and Extra Delivery

(28A) - Extra Pickup

(28B) - Extra Delivery

(28C) - Diversion Charge

1. Self-storage/mini-warehouse locations. Extra Pickup charges will not apply when the only pickup/delivery is from a self-storage or mini warehouse.
2. Stop offs and Diversions. This item contains the provisions that apply when a shipment is diverted or when additional stops are made to perform extra pickups or deliveries.
3. Stop offs: At the request of the Government (either through the pre-approval process or by adding the extra pickup/delivery address in block 13 of the BL), extra stops will be made at locations necessary to accomplish the extra pickup or extra delivery of portions of the shipment.
 - a. Extra stops are additional pickups made after the first pickup or additional deliveries made prior to the final delivery of the shipment. Each such extra stop shall constitute an extra pickup or delivery. An extra stop off fee will apply for each extra pickup or delivery that is performed, in addition to the transportation and additional service charges provided in subparagraphs b and c below.
 - b. Transportation charges on shipments with extra pickups or extra deliveries is determined based on the weight of the total shipment, including any additional weight picked-up or delivered at any stop off(s), rated on BPC miles from the requested pickup (block 19 of the BL) and to the requested delivery address (block 18 of the BL), at the time the

shipment is offered and accepted by the TSP, via any stop off point(s) authorized in Block 13 of the BL or through the pre-approval process.

- c. The rates for additional services performed in conjunction with any extra
 - 1) pickup(s) will be based on the rates applicable at shipment origin and
 - 2) delivery(s) will be based on the rates applicable at shipment destination.
- 4. Diversions:
 - a. The term diversion as used herein means either a change
 - 1) while enroute to the destination of the shipment outside of the BPC of the original destination, or
 - 2) in the route at the request of the Government.
 - b. Upon instructions from the Government, the shipment will be diverted subject to the following terms and conditions:
 - 1) When the TSP receives an order for diversion (TSP may require that all such instructions be in writing), diligent effort will be made to locate the shipment and effect the change desired. The TSP is not responsible for failure to effect the change ordered, unless such failure is due to error or negligence on the part of the TSP.
 - 2) The transportation charges on shipments diverted to a new destination, while the vehicle is enroute or upon arriving at the original destination will be determined based on the total transportation charge from the shipment origin to the point where the shipment was diverted, plus the transportation charge from the point where the shipment was diverted to the final destination.
 - c. On shipments diverted to a warehouse for SIT at a location other than the original destination, the warehouse will be considered the destination point. Transportation charges to the warehouse will be assessed under the provisions of paragraph 3.c. of this item. Charges for storage and further transportation will apply based on the rates and charges named in this Tariff.
 - d. A shipment is not considered a diversion if the change is received prior to the movement of the shipment or if the shipment is in SIT at destination.
 - 1) For delivery out of destination SIT, shipments will be paid according to charges for further transportation in Item 210 and subject to the discounts in effect on the BL that brought the shipment into SIT.
 - 2) The rate (discount) that will apply on shipments placed in SIT within the AOR of the installation or address in block 18 of the BL will be the rate (discount) that applied on the original BL, even if such warehouses cross into a different rate area (a.k.a. Region).
 - e. If a PPSO requests delivery out of SIT to a location greater than 50 miles (a.k.a. long delivery out of SIT) the TSP will agree to deliver the shipment under the same BL that brought the shipment into SIT. No additional documentation will be provided, and the TSP will bill the additional transportation charge utilizing Item code 210C.

- f. This item applies when the TSP furnishes diversion services to redirect a shipment from one original destination to a new destination. This charge reimburses the TSP for all documentation/administrative services associated with the diversion of a shipment. TSP will bill Diversion (28C) Charges utilizing Item 28B (adding a note identifying request is for a diversion) until further notice.

Item 29 - Tender of Delivery for all Domestic shipments

1. TSP must notify the PPSO that a shipment has arrived at destination by arriving the shipment in DPS and providing first available delivery date within one workday after arrival at agent's facility.
2. If the customer is available to receive property on the TSPs first available delivery date, then SIT is not authorized.
3. The PPSO will furnish delivery instruction or SIT approval within 2 hours of shipment arrival in DPS. Prior to approving SIT PPSOs should monitor their "Inbound" DPS queues to ensure TSP has arrived the shipment in DPS.
4. SIT, when approved, will always be effective on the TSP's first available delivery date, not the date of notification. SIT in date will be equal to the TSP's first available delivery date.
5. The PPSO may request/authorize waiting time if additional time is required to provide delivery instructions or SIT approval.
6. For shipments being placed into SIT, TSPs must enter the first available delivery date in the "SIT Entry Date" in DPS, (the arrival date should not be entered in this field unless the first available delivery date is the same as the arrival date).

Item 30 - 31 - Reserved for Future Use

Item 32 - Prohibited and Restricted Articles

1. TSP will not accept shipment property liable to contaminate or otherwise damage equipment or other property, nor will TSP accept shipment articles which cannot be taken from the premises without damage to the article or the premises. TSP will not accept perishable articles including frozen foods, articles requiring refrigeration or perishable plants except as provided in paragraphs 2, 3, or 4.
2. Frozen food will be accepted for transportation provided
 - a. the food is contained in a freezer, which at time of loading is at normal deep freeze temperature,
 - b. the shipment will be transported not more than 150 miles and/or delivery accomplished within 24 hours from time of loading,
 - c. no storage of shipment is required, and
 - d. no preliminary or enroute servicing by use of dry ice, electricity, or other preservative methods is required of the TSP.
3. Perishable plants will be accepted for transportation provided
 - a. the shipment is transported not more than 150 miles and/or delivery accomplished within 24 hours from the time of loading,

- b. no storage is required, and
 - c. no preliminary, enroute servicing, watering, or other preservative methods are required of the TSP.
4. TSP will not be responsible for any perishable article included in a shipment without the TSP's knowledge.
 5. TSP will not accept for shipment under any circumstances tanks or bottles designed to contain butane or propane, including tanks and containers for gas barbecue grills, torches, tools, or appliances. This prohibition also includes tanks or bottles that have been certified as empty.
 6. Refer to the DTR Part IV regarding hazardous materials.

Item 33 - Impractical Operations

1. Nothing in this Tariff shall require the TSP, TSP's hauling contractors, TSP's customers, or TSP's agents to perform any service at any point or location where, through no fault or neglect of the TSP, the furnishing of such services are impracticable because
 - a. conditions of roads, streets, driveways, alleys, or approaches thereto would subject operations to unreasonable risk of loss or damage to life or property,
 - b. loading or unloading facilities are inadequate,
 - c. any force majeure, war, insurrection, riot, civil disturbance, strike, picketing, or other labor disturbance would
 - 1) subject operations to unreasonable risk of loss or damage to life or property, or
 - 2) jeopardize the ability of the TSP to render linehaul, pickup, delivery, or any other service from, to, or at other points/locations,
 - d. local, state, or federal restrictions, regulations, or laws prohibit performance of such services by linehaul equipment,
2. TSPs can utilize third party service, see Item 35, to accomplish these tasks when necessary and approved by the Government.

Item 34 - Reserved for Future Use

Item 35 - Third Party Service Charges

(35A) - Third Party Service (TPS)

(35B) - Service Charge: Florida Keys

1. This item applies when pre-approval has been provided by the PPSO for the TSP to obtain services for the completion of the move. These services include, but are not limited to third party charges, tolls (bridge and ferry), parking permits, and any other services not otherwise identified in this Tariff but requested and approved by the PPSO as necessary for the completion of the move.
 - a. All such third-party charges will be supported by paid receipts and apply in addition to all other applicable tariff charges provided that pre-approval for services has been authorized.

-
- b. Toll charges will be advanced by the TSP, for expenses incurred by the TSP as a result of transiting bridges or ferries that are subject to officially assessed federal, state, county, or local use fees. Tolls will be reimbursed based on TSP providing original receipts from the authorized bridge or ferry toll locations. TSPs are only authorized reimbursement one time per receipt (e.g., if there are more than one shipment on the equipment, the TSP can only file for reimbursement on one shipment and not several).
2. Shipments transported from or to Zip3 of 330, will be subject to a Florida Keys Service Charge. This charge shall apply in addition to any applicable bridge and ferry charges, based on the weight at which the linehaul transportation charges are computed.
 - a. Shipments destined for Florida Keys, FL (with ZIP3 beginning with 330) that are intransit and do not have a direct delivery address, will be assessed by JPPSO Southeast for possible diversion to the Miami or surrounding metropolitan area (with ZIP3 of 331) for SIT.
 - b. JPPSO Southeast will communicate diversions by issuing a BL correction notice indicating "This is a Diversion to Storage-in-Transit in the Miami or surrounding metropolitan area (with ZIP3 of 331) and that 400NG Items 28C para. 4 (Diversion), Item 35B (Florida Keys Service Charge), and Items 210C (Delivery Out SIT over 50 miles) apply."
 - c. Delivery addresses in DPS should continue to show Florida Keys (not Miami or surrounding areas) to avoid inadvertent change of the responsible office to USCG Miami; however, correction notices will reflect storage in transit in Miami or surrounding metropolitan area (with ZIP3 of 331).
 - d. Shipments that receive a delivery address after pickup and the customer is available to accept delivery before arrival at the diversion point should be delivered to the address requested and not be placed into SIT.
 - e. For all shipments diverted under this guidance and delivering out to ZIP3 - 330, the invoicing will be in accordance with 2021 400NG Item 28C para. 4 and the TSP will be authorized to bill 210C (Long Delivery Out of SIT) utilizing MISC Item Code with a detailed note.
 3. When the origin or destination of the shipment, or a portion thereof, is located at a point accessible only by the use of a ferry, the following provisions apply:
 - a. The actual ferry charges will be billed by the TSP to the Government as third-party charge as provided herein.
 - b. When TSPs normal linehaul equipment cannot be accommodated by the ferry system, shuttle service will be provided, subject to the charge and provisions named in Item 33, paragraph 1, and Item 125.
 - c. Waiting time charges as provided in Item 120 of this Tariff will apply commencing with the arrival of the TSP's vehicle at the ferry point of embarkation, during the vehicle crossing, and terminating when the vehicle disembarks from the ferry. The allowable free waiting time provisions provided for in Item 120 will not apply during the ferry waiting and transportation period described herein.
 4. FSC is not authorized, and shall not be billed or paid, on third party.

5. Third party does not apply to washers (e.g., front load) and other household articles that require bracing/stabilization (and unbracing/destabilization) of moveable parts in or on such appliances. The cost of this service is considered to be part of the TSPs transportation charge.
6. Crating is not authorized as a third-party charge. When crating is accomplished in combination with a third party (i.e., pool table disassembly), the TSP will be reimbursed for the cost of the crate, not to exceed the authorized cost for same crate size utilizing Item 105. The TSP must provide documentation identifying the crate dimensions and separate costing for the crate. TSPs must bill the appropriate item code 105B and will only be paid according to the charges in Item 105.

Item 36 - 39 - Reserved for Future Use

Item 40 - General Price Adjustment (GPA)

1. This item provides for the mechanism by which USTRANSCOM may choose to apply an adjustment, effective with the new annual rate cycle, to the rates and charges contained in this Tariff based on the application of certain Government cost indices. Decisions on whether to apply the GPA to accessorial items will be evaluated annually and results will be posted on the 400NG Baseline Rates Change Sheet.
2. A periodic GPA may apply on all rates and charges named in this Tariff as provided herein. The GPA calculations will be performed by USTRANSCOM based on an annual review of U.S. Department of Labor indices. USTRANSCOM will announce in this Tariff whether adjustments will be applied, allowing TSPs time to adjust rates as needed prior to DPS Rate Filing. If a GPA adjustment is made, it will be incorporated into the 400NG Baseline Rates and will be effective on May 15th of each year (e.g., May 15th, 2022).
 - a. Applicable U.S. Department of Labor indices are as reported on the Bureau of Labor Statistics <https://www.bls.gov/> website, as follows:
 - 1) Consumer Price Index (CPI) information is based on All Urban Consumers, not seasonally adjusted, U.S. City Average, for all Items (less Food and Energy), Series ID **cuur0000SA0L1E**.
 - 2) Current Employment/Unemployment Index (CEU) information is based on the average hourly earnings of production workers in the National Employment Index for Hours and Earnings, not seasonally adjusted, for Transportation and Warehousing, specialized freight trucking, under NAICS Code 4842, Series ID **ceu4348420008**.
 - b. GPA will be based on the increase in the CEU times .41 (representing the labor portion of carriers' expenses) plus the increase in the CPI times .59 (representing the reciprocal of .41), as specified in paragraph 2.c.
 - c. To determine the GPA to apply, USTRANSCOM will
 - 1) determine the unadjusted indexes for each index (CPI and CEU) applicable at the beginning and at end of the specified 12 month basing period (e.g., July to July),
 - 2) determine the percentage increase in the CEU, subtract the ending CEU from the beginning CEU and divide that answer by the beginning CEU, and then multiply that answers times .41,

- 3) determine the percentage increase in the CPI, subtract the ending CPI from the beginning CPI and divide that answer by the beginning CPI, then multiply that answer times .59, and
 - 4) add the two weighted subtotals together to determine the GPA percentage increase/decrease that may apply.
- d. The GPA and background calculations will be rounded to the 9th decimal place. All final costs will be rounded to the 2nd decimal place (i.e., background data is \$1.245343423, will round in the 400NG Baseline Rates as \$1.25).
- e. Notwithstanding any other provisions of this Tariff, the GPA will not apply to the provisions of third-party charges and valuation, or other areas determined by USTRANSCOM.

Example: (X = index number to be determined as provided herein):

	July	to	July	% Change	times	Factor	=	GPA
CPI =	X		X	X		.59	=	X
CEU =	X		X	X		.41	=	X
GPA Total = X.XXXXXXXXXX GPA								

Item 41 - Economic Price Adjustment

1. Industry associations that represent various TSPs that are not affiliated with an association may submit a request to USTRANSCOM for a price adjustment regarding unusual surges in unforeseen operating expenses (excluding fuel price adjustment).
2. Surges must be extreme or prolonged in nature that causes a hardship on TSPs. The request shall include a proposal for an adjustment, the amount of the adjustment and supporting documentation clearly explaining the need for the increase and how it was derived.
3. Within 30 days upon receipt of the request and complete supporting data, USTRANSCOM will determine whether a price adjustment is warranted. Every effort will be made to develop a fair and reasonable adjustment; however, USTRANSCOM will make the final decision as to whether an adjustment will be made, as well as the amount, if any, of the adjustment.
4. TSPs will continue performance pending a determination of any adjustment and its effective date and thereafter through completion of the annual rate cycle.

Item 42 - 43 - Reserved for Future Use

Item 44 - Holidays

1. Except as otherwise specifically provided in this Tariff, reference to the term "holiday" shall be the date such as the U.S. National or officially declared State holidays are observed.
2. When a holiday falls on a Saturday, the holiday will be observed on the preceding Friday. When a holiday falls on a Sunday, the holiday will be observed on the following Monday.
3. Charges for holidays in this Tariff shall apply only when service is rendered on an observed holiday. Any service performed on a weekend or holiday where the TSP is seeking additional compensation, must be pre-approved by the PPSO.

4. For reference purpose only, U.S. National Holidays are:

New Year's Day	January 1st
Martin Luther King, Jr's. Birthday	The Third Monday in January
Presidents Day	The Third Monday in February
Memorial Day	The Last Monday in May
Juneteenth National Independence Day	June 19th
Independence Day	July 4th
Labor Day	The First Monday in September
Columbus Day	The Second Monday in October
Veterans Day	November 11th
Thanksgiving Day	The Fourth Thursday in November
Christmas Day	December 25th
Inauguration Day	January 20th of each fourth year after 1965, is a holiday for the Washington, DC area only.

Item 45 - Reserved for Future Use

Item 46 - Collection of Freight Charges on HHGs Shipments Involving Loss or Destruction In-Transit

The collection of unearned freight charges under this item is not applicable to shipments in which the TSP has paid Full Replacement Value under 10 USC 2636a on claims for loss or destruction in an amount less than or equal to the TSP maximum liability set forth by this solicitation .

Item 47 - Offset Action Against Transportation Service Providers (TSPs)

1. Currently, DoD approved Third Party Payment System (TPPS) does not have the capability to process administrative offsets under the provisions of 31 USC 3716.
2. By accepting shipments under this Tariff, the TSP gives consent for a representative of the DoD, USCG, General Services Administration (GSA), or other Federal Government Agencies (FGA) to access the TPPS, generate, and approve electronic bills (eBills) in lieu of an administrative offset under 31 USC 3716, and agrees to hold TPPS, or a successor administrator of the TPPS, harmless for any eBills approved, paid, or collected under this provision.
3. Approved eBills paid or collected under this provision by the DoD, USCG, GSA, or other FGA shall be treated as an administrative offset for the purpose of appeals and refunds.

Item 48 - 49 - Reserved for Future Use

Item 50 - Effective Date Governing Application of Rules, Rates, and Charges of this Tariff

Except as otherwise specifically provided in this Tariff, all rules, rates, and charges in effect on the date shipment is picked up shall apply.

Item 51 - 55 - Reserved for Future Use

Item 56 - Rates Based On Minimum Weight or Minimum Volume

1. Except as otherwise specifically provided for in this Tariff, transportation charges for shipments of individual customers as described in Item 100, paragraph 2.a. of this Tariff are based on minimum weights or volume. TSP must indicate on the BL the minimum weight or volume, base rate, and the minimum charges applicable to the shipment.
2. If TSP fails to comply with the provisions of Item 56, Paragraph 1 the minimum weight or volume provisions will not apply, and in lieu thereof, the actual weight or actual volume of the shipment will be used to determine the applicable transportation charges.
3. The transportation charges, and all other charges based on weight, are based on the weight of the shipment with the following minimums: HHGs 1,000 lbs net.

Item 57 - Reserved for Future Use**Item 58 - Removal or Placement of Property from or to Inaccessible Locations**

1. It is the responsibility of the customer to make property available to the TSP and to remove and place property from or to attics, basements, and other locations where the location of property and goods to be shipped or delivered
 - a. is not accessible by a permanent stairway (does not include ladders of any type),
 - b. is not adequately lighted,
 - c. does not have a flat continuous floor, and
 - d. does not allow a person to stand erect.
2. If the Government requests and TSP agrees to removal or placement of property from or to such areas not readily accessible, Item 120, Labor Charges will apply for this service, and pre-approval is required.

Item 59 - 99 - Reserved for Future Use**Item 100 - Classification of Articles (Commodity Description)**

1. The description of property to which rates, charges, rules, and regulations apply is that class of property designated as a commodity under the following commodity description: Used HHGs consisting of personal effects and property used or to be used in a dwelling when a part of the equipment or supply of such dwelling.
2. 1st Proviso - HHGs: The term 'HHGs', as used in connection with transportation, means personal effects and property used or to be used in a dwelling, when a part of the equipment or supply of such dwelling, and similar property if the transportation of such effects or property is:
 - a. Arranged and paid for by the householder, except such term does not include property moving from a factory or store, other than property that the householder has purchased with the intent to use in his or her dwelling and is transported at the request of, and the transportation charges are paid to the TSP by, the householder.
 - b. Arranged and paid for by another party.

Section 2: Additional Services

Item 101 - 104 - Reserved for Future Use

Item 105 - Packing and Unpacking Services

(105A) - Full Pack/Full Unpack

(105B) - Pack Regular Crate

(105D) - Debris Removal Within 30 Days

(105J) - Storage Inspection Fee (in lieu of full pack ONLY)

1. Pack, Regular Crate, Unpack Regular Crate, and Debris Removal Within 30 Days (after the day of delivery) require pre-approval from the Government or must be Government requested.
2. Anytime the TSP performs packing, unpacking, crating, or uncrating service for the shipment the following will apply:
 - a. Packing/crating charges, except as otherwise provided, apply at the location where the service is provided based on block 19 of the BL at the time the shipment is offered and accepted by the TSP.
 - b. Unpacking, uncrating (charge is included in the crating rate), except as otherwise provided, will be approved by the PPSO, and based on block 18 of the BL at the time the shipment is offered and accepted by the TSP.
 - c. TSP's Linehaul discount (dLHS) will apply to the total of Full Pack/Full Unpack charge.
3. Full-Service Pack/Full Unpack:
 - a. The charges in this part apply based on the net weight of the shipment utilizing a hundredweight (cwt) basis for complete (full pack) shipments.
 - b. The weight of motor passenger vehicles (automobiles, pick-up trucks, vans, sport utility vehicles, dune buggies, and specialty motor vehicles).
 - 1) Will be deducted from the shipment weight prior to determining the Full-Service Pack and Unpack charges.
 - 2) Weight substitution:
 - a) TSPs may substitute the manufacturer's weight in lieu of obtaining separate weight tickets on these articles whenever such articles are included within a shipment.
 - b) Manufacturer's weight will be obtained from either the
 - 1 Branham Automobile Reference Book,
 - 2 NADA Official Used Car Guide,
 - 3 other appropriate reference sources of manufacturer's weight, or
 - 4 customer may provide the TSP with copies of manufacturer's documents evidencing the weight of the article included in a shipment.

-
- c. Consists of packing and unpacking of all such cartons and containers, and debris removal on the day of delivery.
 - 1) Includes all of the cartons, containers, and packing service required and provided by the TSP to pack the shipment for domestic transportation.
 - a) Rates provided apply only for cartons and containers that are furnished by the TSP and not those provided by the customer.
 - b) Rates provided do not apply for containers or cartons that are supplied but not packed by the TSP.
 - 2) Customer is authorized to retain all cartons and containers and may elect to surrender all or a portion of cartons and containers to the TSP at delivery.
 - d. Charges do not include crating service and will not apply on shipments that the TSP does not pack (e.g., shipments released from NTS, shipments from SIT where the BL has been terminated).
 - e. Full Pack: Applies when the TSP furnishes cartons and performs the packing of some or all of the articles in the shipment. The rates contained in the rating engine include the containers, cartons, and packing materials. TSPs filing Code 2 rates are responsible for providing this service at no additional cost beyond the rate on file with the exception of any approved domestic accessorial.
 - 1) Only when packing is performed:
 - a) The Government will pay for full packing and full unpacking and the TSP will provide the applicable service at origin and destination.
 - b) Custom Pack and Custom Unpack will not apply to DoD shipments.
 - 2) Repacking customer cartons under Full-Service Pack.
 - a) TSP, to ensure safe transportation, is required to repack cartons or containers that have been packed by the customer, and
 - b) Item 120 Extra Labor rates will apply for the time spent unpacking such customer-packed cartons (however, no additional repacking or carton charges will apply for such cartons because these charges are already included in the Full-Service Pack charges for the shipment).
 - 3) In lieu of Full Pack, a Storage Inspection Fee (105J) per actual net cwt will apply for shipments that pickup from storage warehouses and are already packed.
 - a) When billing for Item 105J (Storage Inspection Fee) in lieu of 105A (Full Pack), the appropriate Full Unpack amount is due and should be billed as Miscellaneous item code with detailed notes until otherwise announced.
 - b) 105J is not subject to a TSP's dLHS; however, the Full Unpack is always subject to the TSP's dLHS.
 - c) Billing of both item 105A and 105J should not occur on the same shipment.
 - 4) Full Unpack: Only when unpacking is performed (or is waived by the customer):

-
- a) Charges for Full Unpack are based on 25% of the Full Pack rate at the destination schedule (as identified in block 18 of the BL at the time the shipment is offered and accepted by the TSP) for regular time, which is then discounted by 58%.
 - b) The Full Unpack rate line is always the rate line for Full Pack cwt 16,000 lbs and under located in the 400NG Baseline Rates.
 - c) TSPs refusing to unpack customer's shipment or not following the unloading and unpacking requirements outlined in TOS (i.e., meeting the customer's expectation) are not authorized to bill for unpacking services.
- 5) To be paid for services rendered on shipments that are terminated after packing has begun but before shipment departs the origin primary pickup address:
- a) TSP is required to submit a legible inventory, signed by the customer, or designated representative, and approved by the shipping office, of all items packed, disassembled, or prepared for movement,
 - b) TSP will be compensated for packing/unpacking charges based on all items packed, disassembled, or prepared for movement and listed on the inventory by cu ft. of the items, and
 - c) TSP must obtain the cubed weight for authorized items utilizing the weight estimator located at <https://www.ustranscom.mil/dp3/weightestimator.cfm>. For items not covered in the weight estimator, the cube will be converted to a weight basis using 7 lbs. per cu ft. to include PBP&E.
4. Crating Service: Applies when the TSP is requested to provide new crates and is based on the gross measurement of the crate (subject to a minimum charge based on 4 cu ft.). Crating of HHGs may be authorized when standard packaging will not adequately protect an item from damage during transit.
- a. TSPs should consider the type of movement when requesting crating. An item may require crating on a van shipment, but a carton might suffice in a containerized shipment.
 - b. Requirements for crating must be closely scrutinized to prevent unnecessary requests for crating.
 - c. Guidance on crating:
 - 1) when crating may be approved:
 - a) Only those items that have unique features will be approved for crating. Features such as leaded glass or curved glass panels that cannot be duplicated without great expense could be justification for crating.
 - b) Items such as marble tabletops and pool table slates may be too heavy or large for available cartons and are eligible for crating.
 - c) TVs: Crating charges may only apply to flat/curved screen televisions in excess of a 75-inch diagonal screen size.
 - 2) When crating may NOT be approved:

-
- a) Crating furniture items such as rugs, sofas, tables, chairs, buffets, grandfather clocks, and other like items unless, there are unique features easily susceptible to damage.
 - b) A customer's request to crate items declared to be of extraordinary value but lacks appraisal and/or is missing features that cannot be duplicated without great expense.
 - c) Flat/curved screen televisions with a 75-inch diagonal screen size or less.
 - 1 No additional compensation will be provided for flat/curved screen television cartons or containers.
 - 2 The customer shall be responsible for the servicing of such a television at origin and destination, including all associated connection/disconnection and mounting/un-mounting costs.
 - 3 TSPs may utilize the customer's previously used shipping container, if available and serviceable, at no cost to the Government.
5. Packing service charge for crates includes construction, packing, and uncrating.
- a. If origin PPSO approves Item Code 105B, uncrating services are included and mandatory at destination, unless the customer authorizes the TSP not to uncrate.
 - b. When awarded as a Code D shipment, crating of bulky article items (Item 130) are at the discretion of the TSP and no additional cost to the shipper or customer.
 - c. When awarded as a Code 2 shipment:
 - 1) Additional crating may be approved for items that cannot fit into an SDDC approved container or a Portable Moving & Storage Container (e.g., 7 feet x 8 feet x 8 feet at 448 cu ft.).
 - a) All crating shall be done at origin residence in order for the TSP to be compensated for labor or new material unless containerization at the origin warehouse is authorized by the customer or servicing PPSO.
 - b) All uncrating shall be done at the destination residence.
 - c) Crates will be constructed in such a manner that they may be reused by the customer for future moves.
 - 1 TSP shall uncrate item(s) ensuring that component parts of the crate are not destroyed during disassembly and crate may be reused by the customer for future moves.
 - 2 Crates will remain the property of the customer.
 - 3 If the customer elects not to retain the crate, TSP shall remove the crate from the residence.
 - d) Memory Foam Mattresses - Tempur-Pedic or comparable mattress(s) - will be shipped utilizing best commercial practices. Crating at Government expense is not authorized for shipping mattresses via any domestic COS.

-
- d. The rating engine includes charges for crating and only those charges from this Tariff will apply.
 - 1) TSPs must bill the appropriate item code 105B and will only be paid according to the charges in Item 105.
 - a) Crating is not recognized as a third party.
 - b) In the event the TSP does not possess qualified personnel to construct required crates, TSP will, upon request of the Government, be responsible for obtaining a qualified representative to construct such crates.
 - c) Internal and External Crates: No rounding of cubic dimensions is allowed. Number will be truncated at the second decimal (e.g., 6.8055555 cu ft. will be invoiced in DPS as 6.80 cu ft.). Packing and unpacking rates for crate will apply per each cu ft. or fraction thereof based on the gross measurement of the crate.
 - d) TSP must annotate the actual dimensions of the item in their pre-approval request in DPS.
 - 2) Billing:
 - a) TSP must bill either the actual cu ft. of the crate, or the cu ft. limitation listed here, whichever is less.
 - b) Internal Crate:
 - 1 When awarded as a Code 2 shipment, internal crating (Item 105B) may be authorized at the discretion of the Government and must be pre-approved prior to performing the service.
 - 2 Regardless of the actual cu ft. of the crate provided, compensation for internal crates will not exceed 3 inches beyond any single dimension (length, width, or height) of the item being crated. For example: An invoice for an internal crate for an item with dimensions of 39-inch x 71-inch x 0.5 inch will not exceed 42-inch x 74-inch x 3.5 inch, or a total 6.29 cu ft. (subject to a minimum charge based on 4 cu ft.).
 - c) External Crate: Regardless of the actual cu ft. of the crate provided, compensation for external crates will not exceed 5 inches beyond any single dimension (length, width, or height) of the item being crated (subject to a minimum charge based on 4 cu ft.).
 - d) When customer furnishes crate for TSP to pack items, TSP may only charge labor for the sealing of container and uncrating.
 6. Debris Removal charges apply when the PPSO requests that the TSP perform debris removal of unpacked cartons after the date of delivery and the service is performed within 30 days of delivery date.
 - a. Utilized by exception only as provided by Services guidance (e.g., Bluebark, etc.) and only upon specific request and pre-approval by the PPSO/PPPO.
 - b. Performed in conjunction with unpacking service and a debris removal charge will NOT APPLY for the cartons unpacked by TSP at the time of delivery.

- c. Must be performed within 30 days of delivery date.

Item 106 - 119 - Reserved for Future Use

Item 120 - Extra Labor, Special Services, and Waiting Time

(120A) - Extra Labor Regular

(120B) - Special Services

(120C) - Wait Time Labor Regular

(120D) - Extra Labor Regular - OT

(120E) - Special Services - OT

(120F) - Wait Time Labor – OT

1. All items in this section require pre-approval from the Government or must be Government requested. Charges do not apply on Sundays or on National or State holidays, except when a Sunday or holiday pickup or delivery is specifically requested by the shipper. Refer to Item 44 for definition of holidays.
2. Extra Labor, Special Services, and Waiting Time: This item applies when the TSP provides extra labor, special services (such as disassembling or assembling unusual articles) or waiting time that are not included in the transportation charges and for which there are no other applicable charges in this Tariff.
3. The hourly rates named herein will apply for services performed by the TSP, except as otherwise specified herein.
 - a. Rates apply based on the location where the service is performed, pursuant to the Stop Off provisions of Item 28.
 - b. For applying charges for fractions of an hour for all services provided for in this item, refer to Item 22.
4. Extra Labor
 - a. Extra Labor charges apply per worker per hour on both a regular time and an OT basis.
 - 1) Regular time rates apply when service is provided between 8:00 a.m. and 5:00 p.m. Monday through Friday, excluding holidays.
 - 2) Extra Labor Regular - OT is a part of the total Extra Labor and is not accounted for under the Item 175, OT Loading/Unloading. Regular time and OT rates apply, based on the time of the day and the day of the week that the service is performed. Extra Labor Regular - OT hours apply when extra labor service is performed
 - a) between 5:00 p.m. and 8:00 a.m. Monday through Friday, excluding holidays,
 - b) during any hour on Saturdays, Sundays, or holidays, or
 - c) during any hour on Good Friday when service is provided in the New York City area (BPCs: 100 through 127).
 - b. PPSO may authorize additional labor in the handling of gun safes over 300 pounds. If approved, labor will be billed utilizing Item 120 Extra Labor (with an EDI billing note

explaining use).

5. Removing and/or Disassembling and Reassembling

a. The transportation charges in this Tariff do not include any special services or labor required to:

- 1) Remove any article(s) embedded in the ground or secured to a building (i.e., floor, ceiling, roof, or wall), or
- 2) Disassemble or reassemble any article(s), including, but not limited to, steel utility cabinets, swing sets, sky rides, jungle gyms, German shrank, steel shelving, pool tables, elongated worktables, counters, or other articles of an unusual nature, to ensure their safe transportation.

b. TSP will provide such special services at the rates named in this item (See note 1).

6. Appliance and Other Household Articles - Service and Re-Service

a. The transportation charges in this Tariff include only services performed by the TSP to accomplish the bracing/stabilizing (and unbracing/destabilizing) of moveable parts in or on appliances and other household articles (including, but not limited to, refrigerators, deep freeze cabinets, cooking ranges, dishwashers, washing machines, clothes dryers, stereo systems, radios, record players, television sets, and air conditioners), which if not properly serviced prior to loading could be damaged in or incident to transit.

b. Third Party does not apply to washers (e.g., front load) and other household articles that require bracing/stabilization (and unbracing/destabilization) of moveable parts in or on such appliances. The cost of this service is considered to be part of the TSPs transportation charge.

c. Servicing and re-servicing of appliances and other household articles does not include,

- 1) any special service or labor (plumbing, electrical, carpentry, gas, or ventilation connections, etc.) required to disconnect or reconnect such appliances and other household articles from or to the premises, and/or
- 2) any preparation of article(s) by a third party to permit the safe transportation of the article(s), which if not properly serviced prior to loading, could be damaged in or incident to transit. Does not apply to washing machines (e.g., front load washers).
- 3) TSP will provide such special services or labor, mentioned in (1) above, at the rates named in this item (see note 1 and para 2.b. above), subject to the TSP's ability to furnish qualified personnel.

7. Rigging, Hoisting, and Lowering Service

a. If, in the judgment of the TSP, it is necessary to use rigging, hoisting, or lowering services in order to accomplish the pickup or delivery of the shipment, or any portion thereof, TSP will perform such services at the rates named in this item and the TSP's ability to furnish equipment and qualified personnel (see note 1).

b. If TSP is unable to furnish or secure the equipment or qualified personnel, the TSP will be responsible for arranging such service.

8. Waiting Time

-
- a. Charges for waiting time apply on an hourly basis for each hour that the TSP provides waiting time service. A combined charge will apply per hour for each vehicle, each driver, and each helper furnished by the TSP.
 - b. Waiting time is a service that is subject to the availability of the TSP to perform such service and performed beyond the free waiting times indicated in this item.
 - c. Charges for waiting time, when not the fault of the TSP apply between the hours of 8:00 a.m. and 5:00 p.m. only (see paragraph 8.e.), subject to an allowance of 2 hours of free waiting time at destination.
 - 1) After the expiration of the 2 hours of free waiting time, additional waiting time will be provided at the charges named herein, subject to the TSP's convenience.
 - 2) If TSP is unable to provide additional waiting time, the shipment may be placed into storage, pursuant to Item 17.
 - d. For pickups the TSP is responsible for coordinating the pickup with the customer and 1-hour free waiting time shall be allowed at origin.
 - e. When the shipment is delivered from SIT under the provisions of Item 210 of this Tariff and delivery was scheduled by the PPSO the allowable free waiting time is 1 hour (see Item 17-1).
 - f. When the origin or destination of the shipment, or a portion thereof, is located at a point accessible only by the use of a ferry, the following provisions apply:
 - 1) The actual ferry charges will be paid by the TSP and billed to the shipper as an additional charge when supported by a paid receipt.
 - 2) When TSP's normal linehaul equipment cannot be accommodated by the ferry system, shuttle service will be provided, subject to the charge and provisions named in Item 125.
 - 3) Waiting time charges as provided herein will apply commencing with the arrival of the TSP's vehicle at the ferry point of embarkation, during the vehicle crossing, and terminating when the vehicle disembarks from the ferry. The allowable free waiting time provisions will not apply during the ferry waiting and transportation period described herein.
 - g. TSPs may request waiting time in excess of free waiting time for base access delays when wait time exceeds 2 hours for shipments picking up from and/or delivering to a military installation. For delays exceeding 2 hours, a fee of \$75.00 (per instance) will apply and may be invoiced utilizing Item Code 226A (Misc. Charge) with a detailed note explaining the charge. An additional \$18.75 will apply in 15 min increments (i.e., 2 hours 15 min = \$93.75; 2 hours 30 min = \$112.50; 3 hours = \$150.00; 3 hours 30 min = \$187.50; 4 hours = \$225.00; 4 hours 15 min = \$243.75; 5 hours = \$300.00, etc.) (Note: this fee is only for base access delays). Upon notification from the TSP, PPSO/PPPOs will validate specific conditions at the affected installation (e.g., review force protection changes, physical choke points and delays associated with accessing the start of security checks, etc.).
 - 1) Waiting time will not be authorized if delays are in any way due to TSP/agent actions.

- 2) Waiting time does not apply to port agents who pick shipments up from and/or deliver to the Aerial Port of Debarkation/Aerial Port of Embarkation and/or the Surface Port of Debarkation/Surface Port of Embarkation.
- 3) This charge will only be authorized one time per shipment location (e.g., once at origin and once at destination). For example, if a TSP has a 3-day pack out and all three days the TSP/agent encounters long waiting lines, the TSP will only be paid for 1 day of waiting time the other days will not apply.
- 4) Free waiting time at residence of up 1 hour still applies.

Note 1: All third-party charges are in addition to all other applicable tariff charges. A paid receipt shall support such charges provided that the Government pre-approved such services prior to services being performed, subject to the provisions of Item 35. When the TSP bills for Item 120B, third party charges will not apply.

Item 121 - 124 - Reserved for Future Use

Item 125 - Shuttle Service

(125A) - Shuttle Service

(125C) - Shuttle Service - OT

1. All Shuttle Services require pre-approval from the Government. The request must include comprehensive notes explaining the limitations preventing the linehaul equipment from accessing the origin/destination. Valid limitations include but are not limited to the following:
 - a. Structure of the building.
 - b. Inaccessibility by highway.
 - c. Inadequate or unsafe public or private road.
 - d. Overhead obstructions.
 - e. Narrow gates.
 - f. Sharp turns.
 - g. Trees, shrubbery.
 - h. Deterioration of roadway due to rain, flood, snow.
 - i. Nature of an article or articles included in the shipment.
2. This item applies when:
 - a. TSP requests shuttle service for pickup or delivery occurring at a location preventing the linehaul equipment from accessing the origin or destination.
 - b. TSP performs a truck-to-truck transfer only.
 - c. PPSO approves the TSP request, and the customer signs the pickup/delivery documentation, or inspection by PPSO personnel will validate the performance of the service.
3. Shuttle Service does not apply when:

-
- a. The shipment is taken from the residence to await linehaul transportation. Only in unusual circumstances, the Government may approve a shuttle service request.
 - b. Delivered from SIT, shuttle service will not normally be approved.
 - c. When the shipment is picked up by the TSP/agent or delivered from SIT, shuttle service will not normally be approved, unless there are unusual circumstances, and the Government has reviewed and approved the request.
4. Except as otherwise provided, Shuttle Service charges include the cost of the shuttle vehicle and labor required to perform the shuttle service and shall apply:
- a. At the point where the service is performed.
 - b. Shuttle Service charges and/or extra labor charges, shall be in addition to all other transportation or accessorial charges.
 - c. The charges provided are applicable when shuttle service is performed at job sites (residences or storage locations) where the shuttle vehicle is provided or obtained.
 - d. Pursuant to Item 18, DTOD mileage will be used when shuttle service is performed within the same BPC and is then manually looked up and keyed into the rating engine.
 - e. When Shuttle Service OT is requested by the Government,
 - 1) OT charges apply when service is performed between 5:00 p.m. and 8:00 a.m., Monday through Friday, or at any time on Saturdays, Sundays, and holidays.
 - 2) OT charges will not apply when service is performed for TSP's convenience.
 - 3) OT charges provided for herein are applicable ONLY for the shuttle service operation; refer to Item 175, OT Loading/Unloading, for additional OT charges that may also be applicable.
 - f. Based on the weight of the shipment, or portion thereof that is transferred to/from linehaul equipment to/from a smaller truck, subject to a minimum weight of 1,000 lbs.
 - 1) Separate weight tickets are required for shuttle services comprising a portion of a shipment and in excess of 1,000 lbs.
 - 2) Failure to provide a separate weight ticket in such circumstances will limit compensation to 1,000 lbs.
5. Nearest point of safe approach:
- a. The customer is responsible to make the shipment accessible to the TSP or accept delivery from TSP at a point at which the normally assigned linehaul vehicle/equipment may be safely operated.
 - b. TSP shall hold itself available at point of pickup or tender delivery at destination at the nearest point of approach to the desired location where the linehaul vehicle/equipment can be made safely accessible.
 - c. If the customer does not accept the shipment at the nearest point of safe approach, the TSP, upon Government approval, may place the shipment or any part thereof not reasonably possible for delivery, in storage at the nearest available Government Item

approved warehouse of the TSP. The transportation charges to cover the movement of shipment shall be

- 1) computed based on weight of shipment being delivered, and
 - 2) the mileage will be limited to 0-30 miles (Item 210A) and will be subject to TSPs SIT discount. The responsible PPSO must be informed of such action prior to placement in warehouse.
6. To support payment TSP must submit
- a. a DD Form 619 signed by the customer to validate that requested services were performed and
 - b. weight tickets from the larger vehicle, not the smaller vehicle. Weight tickets will be submitted with the overall shipment documentation (individual shuttle loads do not need to be weighed).
7. The following additional documentation may be requested by GSA and/or PPSO to support payment:
- a. Signed dispatch logs indicating the driver and equipment specifics used to perform the truck-to-truck transfer, with dates.
 - b. Paid equipment rental receipts and/or Driver Cab Logs (whichever is applicable) indicating
 - 1) equipment type,
 - 2) duration of use,
 - 3) date used, and
 - 4) location of use
 - c. Copy of the vehicle registration if a vehicle from an agent was used.
 - d. Rental equipment used for a shuttle is not reimbursable.

Item 126 - 129 - Reserved for Future Use

Item 130 - Light and/or Bulky Article Classifications

- (130A) - Bulky Article: Automobile, Truck, or Van
- (130B) - Bulky Article: Go-Carts, Motorcycle ≥ 250 cc, Riding Golf Cart, Small Rec Vehicle, Snowmobile, Three/Four Wheelers, Riding Lawnmowers (including stand-on)
- (130C) - Bulky Article: Canoes, Jet Skis, Kayaks, or Windsurfers with/without associated trailer
- (130D) - Bulky Article: Boats ≤ 14 ft., Dinghies, Row Boats, Sculls, Skiffs with/without associated trailer
- (130E) - Bulky Article: Boats > 14 ft., Dinghies, Sculls, Skiffs, or Row Boats with/without associated trailer when shipped with household goods
- (130F) - Bulky Article: Trailers Boats ≤ 16 Ft., (Boat trailers are handled under the BOTO program)
- (130G) - Bulky Article: Big Screen TV ≥ 48 In., (excluding flat screen televisions)

- (130H) - Bulky Article: Baby Grand Piano or Grand Piano (excluding upright pianos)
- (130I) - Bulky Article: Animal House/Kennel, Playhouse, Tool Shed, or Utility Shed >100 cu ft. (charges will only apply if item is moved assembled)
- (130J) - Bulky Article: Bathtub, Hot Tub, Jacuzzi, Spa, or Whirlpool Baths >100 cu ft. (charges will only apply if item is moved assembled)
1. All Bulky Article charges require pre-approval from the Government. Billing for Bulky Article will not be allowed for those items approved for crating or shipped as Code 2. Only items specifically listed in this Tariff will be considered as a Bulky Article. Items of similar size and characteristics to Bulky Articles listed above are not eligible for compensation.
 - a. This item applies when a shipment includes light and/or bulky articles (identified above) and includes:
 - 1) Both loading and unloading service. One charge for each time a combined loading and unloading service is required (except as identified below), including shipments requiring SIT (except for TSP convenience).
 - 2) The handling and blocking of such article.
 - b. Bulky Article charges do not apply to:
 - 1) Shuttles when the TSP trans-loads from one vehicle to the other.
 - 2) Articles capable of being safely hand-carried by one person and/or transported in standard cartons except kayaks, canoes, or dinghies.
 2. Determining lengths:
 - a. In determining lengths for the purpose of this item, all fractions of a foot will be disregarded.
 - b. Boats, canoes, skiffs, rowboats, kayaks, sailboats, or jet skis shall be determined by the straight center line distance between the top center point of the transom and a point perpendicular with the foremost part of the bow. Manufacturer's "length overall" or "center line length" shall apply as the correct length for the purposes of this item in lieu of physical measurement by TSP. (See Item 301 for boat on trailer dimensions).
 3. Boats 14 feet or less in length or a boat and its associated trailer with combined length of 14 feet or less, a width of 6 feet 5 inches or less, and a height of 6 feet 5 inches or less, can be transported (e.g., canoe, skiff, dinghy, scull, kayak, rowboat, sailboat, outboard/inboard motorboat) with HHGs or by personally procured transportation.
 4. Boats over 14 feet in length or more than 6 feet 10 inches wide or 6 feet 5 inches high with or without a trailer must be shipped separately under a domestic OTO rate negotiated by USTRANSCOM (unless TSP moving HHGs agrees to move with HHGs and receive the Bulky Article charge) or by personally procured transportation. See Section 3 OTOs (Boat and Mobile Homes) for further guidance.

Item 131 - 134 - Reserved for Future Use**Item 135 - Origin and Destination Service Charge**

- (135A) - Origin Service Charge

(135B) - Destination Service Charge

1. The Origin and Destination Service Charge includes:
 - a. Elevator service.
 - b. Stair.
 - c. Excess distance carries.
 - d. Additional Transportation Charge.
 - e. Bracing and stabilization (and unbracing/destabilization) of moveable parts in or on household appliances (see Item 35 and 120).
2. This item applies at the requested pickup address (block 19 of the BL) and/or the requested delivery address (block 18 of the BL) at the time the shipment is offered and accepted by the TSP and applies for the handling and servicing of the shipment at each location.
3. All shipments shall be subject to an Origin and Destination Service Charge, which shall apply once at origin and once at destination based on the net weight of the shipment (see Para 5. and 7. in this item), on a per cwt basis.
4. These charges shall be in addition to all other transportation or accessorial charges.
5. Additional Stops: On shipments picked up or delivered at more than one place, the initial point of origin shall be the basis for the determination of charges at points of extra pickup, the final point of delivery shall be the basis for the determination of charges at points of extra delivery and the total (combined) net weight of the shipment shall be the basis for the determination of charges under this item.
6. Diversion: The requested pickup address (block 19 of the BL) and/or the requested delivery address (block 18 of the BL) at the time the shipment is offered and accepted by the TSP (not the point of diversion) shall be the applicable points for the determination of charges under this item. On shipments that are diverted back to origin, the Origin Service Charge shall apply twice.
7. SIT: The determination of the charges under this item is based on the requested pickup address (block 19 of the BL) and/or the requested delivery address (block 18 of the BL) at the time the shipment is offered and accepted by the TSP. If the domestic shipment terminates at the storage facility, then the storage site shall be considered the final point of delivery.

Item 136 - 174 - Reserved for Future Use

Item 175 - Overtime Loading and Unloading Service

(175A) - OT Loading/Unloading

1. This item applies at the point where such service is performed, pursuant to the Stop Off provisions of Item 28 when:
 - a. Service is provided on Saturdays, Sundays, holidays, or between the hours 5:00 p.m. and 8:00 a.m. on Mondays through Fridays when this service is made necessary by:
 - 1) Specific request of the shipper, customer, or the customer's agent.

- 2) Landlord requirements.
- 3) Prevailing laws and ordinances.
- b. OT loading and unloading charges applies on Good Friday when service is rendered on that day in the New York City area (BPCs: 100 through 127).
2. This item does not apply when:
 - a. Done either for TSPs convenience or the option of the TSP.
 - b. At destination when First Proviso shipments (as defined in Item 100) are delivered to a storage facility.
 - c. The OT provisions of Item 210 (Pickup and Delivery Transportation Charges on SIT Shipments) or Item 120 are applicable.
3. OT loading and unloading charges will be based on actual net weight subject to a minimum of 1,000 lbs. If only a portion of a shipment is loaded/unloaded a separate weight ticket MUST be provided, otherwise TSP is limited to billing 1,000 lbs.
4. OT loading or unloading services will be performed at a warehouse only when agreed to by the warehouseman.

Item 176 - 184 - Reserved for Future Use

Item 185 - SIT Charges

(185A) - SIT 1st Day

(185B) - SIT Additional Day

1. This item applies when SIT is performed and is subject to the SIT discount (dSIT).
2. SIT charges are in dollars and cents per 100 lbs and apply based on location shown on the BL (block 19 for origin SIT and block 18 for destination dSIT). Charges for this service shall be based on actual net weight of goods stored in transit, subject to a 1,000-lbs minimum, except as described in Item 210.2.
3. Storage charges apply for each day of storage, and apply each time SIT service is rendered. Storage days will include the day the goods are placed in storage, and the day the goods are removed from storage.
4. See tender of service for 24-Hour Notification.

Item 186 - 209 - Reserved for Future Use

Item 210 - Pickup and Delivery Transportation Charges on SIT Shipments

(210A) - SIT Pickup/Delivery 30 Miles or Less

(210B) - SIT Pickup/Delivery 31-50 Miles

(210C) - SIT Pickup/Delivery Over 50 Miles

(210D) - SIT Pickup/Delivery 30 Miles or less (OT)

(210E) - SIT Pickup/Delivery 31-50 Miles (OT)

(210F) - SIT Pickup/Delivery Over 50 Miles (Alaska)

1. This item applies on SIT shipments when the TSP provides pickup or delivery service between the storage location and the residence. TSPs can use any DoD approved storage facility listed in DPS. However, charges will not be based on the actual storage location.
 - a. SIT Pickup/Delivery charges (210A, B, C, or F) are based on either the BPC at the original requested pickup address (block 19 of the BL) or original requested delivery address (block 18 of the BL) at the time the shipment is offered and accepted by the TSP and the distance between those addresses (block 18 for destination SIT and block 19 for origin SIT) and actual residence.
 - 1) Items 210A, 210B, 210C, and 210F do not require pre-approval from the Government unless the following situations exist:
 - a) Delivery out of SIT is greater than 100 miles.
 - b) The customer has Amended Orders changing their assignment to a new gaining organization, unit/company, or installation that is outside of the original destination rate area/region and/or over 100 miles (using BPC or DTOD miles as applicable).
 - 2) If a PPSO does not acknowledge a delivery address change request before the scheduled delivery date, the TSP shall deliver the shipment to meet the customer's expectation. If the address is over 100 miles from block 18 of the BL, the TSP will not schedule delivery out of SIT until the approval has been entered in DPS.
 - 3) When TSP are authorized to bill Item Code 210B, TSPs will combine the charges for Items 210A and 210B and invoice the total as Item 210B. Therefore, TSPs will not bill 210A and 210B on the same shipment.
 - b. Items 210D and 210E require pre-approval from the Government. On SIT Shipments, the OT SIT Pickup or Delivery Service charges provided herein do not apply when the distance between the storage location (as defined above) and residence is over 50 miles. Refer to Item 175, OT Loading/Unloading, for charges that apply.
2. SIT pickup and delivery transportation charges apply for shipments stored in transit based on the SA applicable to block 18 or 19 of the BL at the time the shipment is offered and accepted by the TSP.

When the Distance Between Block 18/19 and the Actual Pickup or Actual Delivery Location is:	The Applicable Charges Are:
Up to 30 Miles	Item 210A
Over 30 Miles - Up To 50 Miles	Item 210A PLUS Item 210B
Over 50 Miles	Item 210C: Use the linehaul tables for computation of charges
Over 50 Miles (Alaska only)	Item 210F: Use the linehaul tables Section 7 Intra-AK

- a. DTOD shall be used to determine the distance-based rates when the original requested pickup address (block 19 of the BL) or original requested delivery address (block 18 of the BL), at the time the shipment is offered and accepted by the TSP, have the same first three digits in their ZIP Codes as the final delivery address.

- b. When shipper requests OT Pickup or Delivery Service, subject to PPSO approval, OT charges:
 - 1) Apply when service is performed between 5:00 p.m. and 8:00 a.m., Monday through Friday, or at any time on Saturdays, Sundays, and holidays.
 - 2) Will not apply when service is performed for TSP's convenience.
- c. SIT Pickup and Delivery charges are subject to the minimum weights as provided for in this Tariff,
 - 1) except for pickup or delivery of portions of a shipment placed into or removed from storage, which are based on actual net weight. See Appendix A for "actual weight" computation charges, and
 - 2) when the portion of a shipment delivering out of SIT is less than 1,000 lbs, TSP should bill the actual net weight using Misc. Item Code (226A) with detailed notes until further notice.
- d. The SIT Pickup and Delivery charges
 - 1) include the loading and unloading of the shipment and the transportation of the shipment from or to the storage facility, and
 - 2) do not include any other Additional Services named in this Tariff.
- e. When the distance between the original delivery address (block 18 of the BL) at the time the shipment is offered and accepted by the TSP) and the actual delivery residence is more than 50 miles,
 - 1) the provisions of this item will not apply, and
 - 2) the applicable transportation rates and discounts in effect on the requested pickup date when the shipment was awarded will apply.
- f. For shipments that are released to dock, the TSP is not authorized this charge.
 - 1) TSP shall submit a pre-approval for labor (Item 120) for placing items on dock.
 - 2) If TSP plans to assist the customer with loading their vehicle, TSP can submit a pre-approval for labor.
 - 3) TSP will be required to submit refund for non-performance of unpacking. The refund shall be the unpack rate for Item 105A.
- g. When a shipment is placed in origin SIT, the shipment movement is terminated, and the delivery is within the local area, after a BL Correction Notice is accomplished with the new delivery address, the TSP is authorized to invoice for
 - 1) delivery into SIT (210A),
 - 2) delivery out of SIT (210A),
 - 3) related FSC, and
 - 4) service charges if applicable.

Item 225 - Pickup and Delivery at Third Party / Self-Storage Warehouses

(225A) - Pickup/Delivery Self/Mini Storage

(225B) - Pickup/Delivery Self/Mini Storage (OT)

1. This item requires PPSO pre-approval and applies, except as otherwise provided herein,
 - a. when TSP picks up/delivers a shipment to/from a third-party warehouse (including self-storage/mini-warehouse locations), and
 - b. the Government requests the TSP to enter the warehouse for the purpose of removing items stored from, or placing items into, the warehouse space rented by the DoD customer.
2. This item does not apply when,
 - a. the "Primary" Pickup (block 19) or Delivery (block 18) is a commercial warehouse rented by the DoD customer, the TSP is required to enter the facility, at no additional cost, to service the shipment, and
 - b. Extra pickup (Item 28) charges will not apply when the only pickup/delivery is from a self-storage or mini-warehouse.
3. Pickup and Delivery charges:
 - a. Charges apply at the point where the service is performed, pursuant to the Stop Off provisions of Item 28, based on the weight of the shipment, or portion thereof, that is placed into or removed from the warehouse, subject to a minimum weight of 1,000 lbs.
 - b. If only a portion of a shipment is loaded/unloaded, a separate weight ticket MUST be provided; otherwise, TSP is limited to billing 1,000 lbs.
4. The OT Warehouse Pickup or Delivery Charges provided for herein are applicable
 - a. OT charges apply when
 - 1) Pickup or Delivery Service is requested by the Government,
 - 2) service is performed between 5:00 p.m. and 8:00 a.m., Monday through Friday, or at any time on Saturdays, Sundays, and holidays, and
 - 3) only for the portion of the pickup or delivery service that is performed inside the warehouse space. Refer to Item 175, OT Loading/Unloading, for additional charges that may apply.
 - b. OT charges will not apply when service is performed for TSP convenience.

Item 226 - Miscellaneous

(226A) - Miscellaneous Charge

Any authorized charge incurred by the TSP that does not have a designated service code, and not performed by a third party, shall be billed as a miscellaneous charge. TSP must submit a detailed note with a description of the service provided.

Item 227 - Alaska and Intra-Alaska Shipments

1. Compensation methodology for all shipments between CONUS and Alaska will be based on the Ocean Waterhaul table utilizing the port of Tacoma, WA as the only CONUS Port of Debarkation/Port of Embarkation.
2. TSP electing to use the Alcan Highway will be compensated based on compensation methodology identified above.
3. Shipments traveling Intra-AK will continue to be based on linehaul mileage compensation and will not be compensated based on the Ocean Waterhaul tables.
4. Bunker Surcharge (BSC) compensation is authorized as below:
 - a. The TSPs must ensure the Ocean Bill of Lading (OBL) invoice has the following:
 - 1) Individual BSC (some OBLs list as FSC) for each BL shipment listed on the invoice,
 - 2) total BSC for all BL shipments on the OBL,
 - 3) net weight of the individual BL shipments,
 - 4) net weight of the total BL shipments, and
 - 5) sail date.
 - b. The OBL must be from the actual ocean carrier. No other parties (i.e., third party, freight forwarders, etc.) will be accepted.
5. The OBL must be provided to JPPSO/PPSO for validation of charges. See Appendix A for computations.
6. The OBL must list the BSC as being from port-to-port (i.e., Port of Anchorage to Tacoma, WA). Port-to-door (i.e., Port of Anchorage to St Louis, MO) BSC will be disputed unless the OBL has the port-to-port BSC listed and calculated separately from the port-to-door BSC.

Item 228 – Special Solicitation (SS) Purpose

This chapter pertains to instructions, information, and procedures on the soliciting and awarding for Special Solicitation (SS) rate areas.

Item 229 – Standards

1. TSPs submitting rates for each SS group must provide rates for and service all channels that comprise the SS group. Failure to successfully file rates for all channels will negate the TSP the opportunity to be selected as the “winner” of the SS group.
2. Rate review:
 - a. TSP rates will be reviewed for consistency with other rates submitted for the same rate area as well as adjacent rate areas.
 - b. Suspect rates will be reviewed by USTRANSCOM on a case-by-case basis.
 - c. TSPs may be required to provide the rate construction breakdown of the suspect rate(s).
 - d. If a rate(s) is deemed to be outside the competitive rate range (e.g., deemed non-compensatory), it will be rejected by DPS.

- e. The rejection of a single rate will be cause for ineligibility of that TSP for the applicable SS group as they would be unable to service all channels in that SS group.
3. TSPs must submit bids based upon the use of agents/warehouses approved for use by the DoD installations responsible for the applicable area.
 - a. TSPs are responsible for validating the selected DoD warehouse(s) is/are approved in DPS prior to filing rates.

Item 230 - Estimated Traffic/Shipments

1. Estimated traffic/shipments are based on historical records.
2. Traffic/shipment data will not be construed as a guarantee by the Government of any volume of traffic.

Item 231 - General

1. These procedures solicit competitive rates for the below SS areas.
2. All shipments will be controlled by various PPSOs dependent upon the customer's duty station.
3. Each channel-COS combination below comprises one unique SS group. Specific channel groupings that comprise each SS are located at <https://www.ustranscom.mil/dp3/pdfs.cfm>.
4. Class 1 SS Groupings:
 - a. COS D CONUS shipments to/from Region 16 rate areas.
 - b. COS 2 CONUS shipments to/from Region 16 rate areas.

Item 232 - Participation and Performance

1. Participation in these requests for quotes (RFQs) RFQs is strictly voluntary.
2. Each Class SS grouping is a winner takes all based on the TSP with the highest overall BVS for the aggregate of all channels in the special solicitation.
3. For Class 1 SS Groups, TSPs may not blackout or refuse shipments on any channels that comprise the SS group once selected as the primary (winner).
4. TSPs participating in the SS program are subject to administrative actions IAW DTR Ch. 402 & Ch. 405.
5. For Class 1 groupings, if the primary TSP (winner) is suspended or placed in non-use, the corresponding sequential TSP (i.e., #2, #3, #4, etc.) will become the primary (winner) TSP for all specific (Market, GBLOC, Channel) SS shipments until suspended or non-use TSP is reinstated, or the rate cycle ends.
6. USTRANSCOM may remove TSPs failing to meet performance standards.

Item 233 – 299 Reserved for Future Use

Section 3: One Time Only (OTO) (Boats and Mobile Homes)

Item 300 - Purpose

1. Unless otherwise stated, all portions of this Tariff apply to Domestic Boat One Time Only (BOTO) and Domestic Mobile Home One Time Only (MOTO) shipments.
2. This chapter provides the procedures and information required for TSPs to file voluntary OTO rates to transport DoD and USCG-sponsored BOTO/MOTO shipments within CONUS (excluding Alaska (BOTO shipments) and Hawaii (BOTO/MOTO shipments) and DC.

Item 301 - Criteria for Use of BOTO/MOTO Rates

1. When the TSP transporting the HHGs does not agree to move a boat (over 14') with the HHGs, BOTO/MOTO rates will be obtained through a competitive bidding process via DPS for the movement of privately owned boats or personal watercraft. with or without an associated trailer over 14 feet in length or over 6 feet 10 inches in width or over 6 feet 5 inches in height and mobile homes.

2. When shipping a boat with a trailer, the overall dimensions of the boat on the trailer as a single unit must be provided, as illustrated below. Please provide this information in the

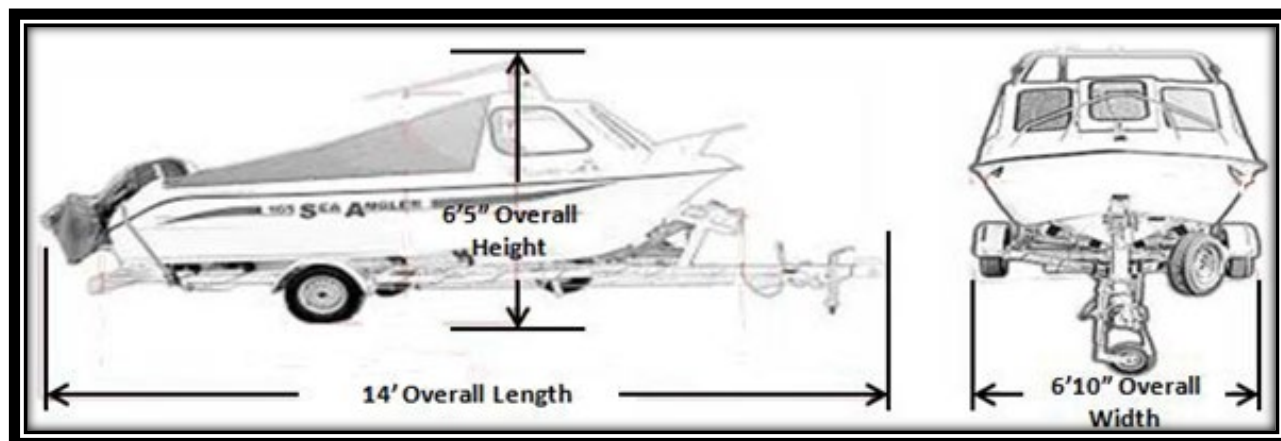

“Additional Remarks” field during counseling, identified as “Boat on Trailer Dimensions.”

Item 302 - Procedures

1. BOTO/MOTO move requests will be created by the PPSO in DPS and sent to USTRANSCOM for review.
2. USTRANSCOM Special Requirements & Rates Team will solicit and award the BOTO/MOTO rate request in DPS.
 - a. Approved TSPs wishing to participate will submit their rates in DPS.
 - b. E-mailed/faxed submissions will not be accepted.
3. Time requirements:
 - a. Customer must provide a minimum of 30 days' notice prior to the requested move date.
 - b. PPSO must provide a minimum of 20 days' notice prior to the requested move date.
 - c. All requests shorter than these timelines must be coordinated directly with USTRANSCOM Special Requirements & Rates Team prior to submission.

Item 303 - Submission of Rates and Charges

1. BOTO/MOTO shipments will operate the same as standard shipments (unless otherwise identified in this section).
2. Rate submission requirements:
 - a. Rates and charges offered in bid submissions must be independently determined and expressed as indicated in Item 303(6).
 - b. Competitive rate bids submitted in response to these filing procedures must be submitted by the Bid End Date/Time and under the terms, conditions, and procedures specified.

-
- c. This solicitation stands alone, is not influenced by prior practices or procedures, and is subject to modification by USTRANSCOM Special Requirements & Rates Team prior to the solicitation Bid End Date/Time or after as needed.
 - d. TSPs can enter only one bid per BOTO/MOTO request and rates must be error-free.
 - 1) The TSP may edit, change, correct, or delete any of their entered information during the bid window.
 - 2) After the BOTO/MOTO Bid End Date/Time, rates are not allowed to be entered into DPS and no changes, withdrawals, or cancellations are allowed.
 - 3) USTRANSCOM is not responsible for rates not entered into DPS prior to the Bid End Date/Time.
 - 4) BOTOs/MOTOs are not restricted by Rate Cycle Dates or Performance Periods.
 - 5) Technological issues may occur when submitting bids.
 - a) TSPs should enter their bid into DPS as soon as possible to meet the Bid End Date/Time.
 - b) If TSPs have DPS issues or discrepancies during the solicitation and bid process it is recommended they contact the DPS helpdesk.
 - 6) Rate will be expressed as a flat rate and will be the prevailing rate. The flat rate will include:
 - a) All costs associated with the movement of the BOTO/MOTO (including but not limited to linehaul, fuel, over-dimensional charges, placement of the load, requested origin and destination accessorial services identified in the BOTO/MOTO solicitation (unless otherwise identified in this Tariff or the solicitation), and Items 400 - 405 of this Tariff).
 - b) The customer is responsible to reconnect/disconnect all utilities and air conditioner.
 - c) SIT Rate will be based on a Daily SIT Rate as identified in the TSPs bid.
 - d) TSP's BOTO/MOTO Flat Rate will apply for each shipment moved until its final delivery to the customer.
 - e. In addition to rates and charges, the TSP must enter the following information for a valid bid to be accepted:
 - 1) The Flat Rate.
 - 2) Tender Number.
 - 3) TSP POC information (name, telephone #, and e-mail address).
 - 4) Cost for any Accessorial charges not identified as included in the Flat Rate (i.e., Tube/Tire repair, Tube/Tire replacement, etc.).
 - f. USTRANSCOM will evaluate all bids received.
 - 1) Acceptance of bid does not guarantee shipment award.

- 2) USTRANSCOM will make every effort to protect the confidentiality of rates submitted; however, no guarantee is expressed or implied.
3. For details on BOTO/MOTO rate filing see the "TSP OTO User Guide".

Item 304 - Terms and Conditions for TSPs Submission

1. TSPs that are in a suspended, non-use, disqualified, or revoked status during any portion of the BOTO/MOTO solicitation will not be considered.
2. The rules and regulations contained in this Tariff provide all terms and conditions and will not be subject to modification prior or subsequent to acceptance of rates unless specifically modified by USTRANSCOM, for the mutual benefit of all parties.
3. USTRANSCOM reserves the right to reject any or all offers and to waive minor irregularities in offers received.

Item 305 - Effective Period for Accepted Bid Procedures Are Applicable for Rates

1. Shipments must be tendered to the TSP prior to the tender expiration date (30 days after originally scheduled pickup date). In the event this cannot be accomplished, USTRANSCOM will notify the TSP and request an extension of the expiration date or solicit a new BOTO/MOTO rate, as appropriate.
2. PPSOs will ensure that any cancellations are effected with the TSP at least 48 hours prior to date of pickup to avoid services ordered, but not used. Any charges for services ordered but not used must be paid IAW the rate tender and/or a negotiated rate obtained by USTRANSCOM.
3. Shipment will be awarded to the TSP with the highest Best Value Score (BVS), for more details on BVS see DTR Part IV Chapter 403.

Item 306 - 314 - Reserved for Future Use

Item 315 - Origin and Destination Services

The TSP shall perform the origin and destination services requested by the PPSO to accomplish the move, utilizing the accessorial stated in this Tariff. Specific requirements for each accessorial are described herein and are included in the Flat Rate bid. If specific instructions or requirements are not provided, the best available and frequently used commercial practices shall be used.

Item 316 - 327 - Reserved for Future Use

Item 328 - Third Party Service

1. When third party service is required for an accessorial service requested in a BOTO/MOTO solicitation,
 - a. the charge will be included in the BOTO/MOTO rate.
 - b. TSP will be responsible for payment of such services without additional reimbursement from the Government.
2. When third party service is requested and approved by the PPSO (i.e., services not known or ordered during initial solicitation)

- a. TSP will engage third party service for performance of special services not included in the BOTO/MOTO rate.
- b. TSP will pay the third party and invoice the charge.
- c. Indicate date, time, and type of service performed on the bill for charges.

Item 329 - Tire/Tube Repairs or Replacements In-Transit

TSPs having to repair and/or replace a tire/tube (Item 419) will invoice using the rate submitted at the Bid End Date/Time.

Item 330 - Tow-Away Boat Service (COS B)

The movement of a boat with trailer by a commercial TSP towed with a self-contained power unit capable of being operated over the highways.

Item 331 - Haul-Away Boat Service (COS H)

The movement of a boat with or without a trailer by a commercial TSP with specialized equipment used to transport boats on cradles, racks, or flatbeds from an origin to a destination. This service is normally for a large boat without a trailer or a boat with non-roadworthy trailer.

Item 332 - 399 - Reserved for Future Use

Section 3A: Included Accessorial Services

The following services are included in all-inclusive flat rate and do not need to be requested by the PPSO and/or customer. TSPs must include the cost for items 400 - 405 in their bid.

Item 400 - Anti-Sway Devices

Cost of rental, labor, etc., for anti-sway devices.

Item 401 - Escort Service

All escort vehicle(s) and driver(s) required to comply with federal, state, municipal regulatory bodies, or as stated on the permits.

Item 402 - Installation of Temporary Lights

Cost of installation of temporary yellow flashing lights on units, a temporary light harness if the unit is not equipped with operative running, stop, or turn signal lights, and special lights in lieu of escorts.

Item 403 - Tolls and Fees

Bridge, road, turnpike, ferry/tunnel charges, surcharges, taxes, permits, and/or fees assessed by any state or local Government through which the shipment must move.

Item 404 - Transit Axles Request

1. Request must include number of axles, braking axles, and tires actually on mobile home. A response of 'none' or a blank response will automatically require rental of tires/axles.
2. Renting axles with wheels, tires, and brakes, if required, along with installation costs to meet the following requirements:

- a. Axles required to meet the manufacturer's requirements of a mobile home when the customer does not provide and/or has an insufficient number of axles to move the home.
- b. Axles that are required to comply with permit requirements of federal, state, or municipal regulatory bodies.

Item 405 - Inventorying

The TSP, in coordination with the customer, shall prepare IAW DTR Part IV, Chapter 402 an accurate legible HHGs descriptive inventory.

Section 3B: Frequently Requested Accessorial Services

The following items may be requested by the customer or the PPSO. TSP must enter the rate for each accessorial item identified in the request; however, the charges will be included as part of the all-inclusive flat rate.

Item 406A - Packing and Related Servicing Requirements

The TSP shall pack and prepare articles IAW DTR Appendix B guidelines.

Item 406B - Unpacking and Related Servicing Requirements

Unloading at destination will be IAW DTR Appendix B guidelines.

Item 407 - Appliance Servicing

The TSP shall service appliances by securing the item in such a manner that it will withstand handling and transportation.

Item 408 - Preparation of Mobile Home for Movement

The TSP shall prepare the mobile home for movement to meet the best commercial practices.

Item 409A - Hitch Installation

TSP shall install customer's hitch on mobile home.

Item 409B - Hitch Removal

TSP shall remove customer's hitch from mobile home.

Item 410A - Unblocking

TSP shall unblock the mobile home. Disposition and/or movement of blocks will be customer's responsibility.

Item 410B - Blocking

The TSP shall block the mobile home. The customer shall be responsible for furnishing blocking material. This service does not include digging ditches, trenches, footers, postholes, or furnishing poles.

Item 411A - Un-anchoring

The TSP shall perform un-anchoring service at origin. This includes removal of the anchors from the ground and disconnection of the straps. If the anchors cannot be removed, they must be sheared off even with the ground.

Item 411B - Anchoring

The TSP shall perform anchoring services at destination. The customer shall be responsible for furnishing the anchoring material.

Item 412A - Removal of Skirting

The TSP shall remove skirting from the mobile home.

Item 412B - Installation of Skirting

The TSP shall install skirting. The customer shall be responsible for furnishing the skirting material.

Item 413A - Expando, Tipout, or Slideout Removal

The TSP shall prepare, separate, and seal each expando, tipout, or slideout unit prior to movement (see Item 413B para. 2.).

Item 413B - Installation of Expando, Tipout, or Slideout

1. The TSP shall secure each expando, tipout, or slideout unit at destination.
2. An expando room that is a separate unit and cannot be slid, tipped, or enclosed within the main body of the mobile home and requires separate transport will fall under the provisions of Items 414A and 414B.

Item 414A - Double-Wide Separation and Preparation for Movement

The TSP shall separate each unit of a double-wide mobile home and prepare for movement.

Item 414B - Reassembly of Double-Wide

The TSP shall reassemble the double-wide mobile home.

Item 415A - Installation of Customer-Owned Axles/Tires

The TSP shall install customer's tires, axles, and grease and service wheel bearings prior to movement.

Item 415B - Removal of Customer-Owned Axles/Tires

The TSP shall remove customer tires/axles at destination.

Section 3C: Specialized Accessorial Services

A rate for each of the following items will be submitted in DPS as part of TSP acceptance of the award.

Item 416 - Extra Axles

When submitting their bid in DPS, TSP will submit a rate for extra axles (for use when the requirement is identified after the bid window is closed). This rate will include installation and rental of axles with wheels, tires, and brakes, as required.

Item 417 - 418 - Reserved for Future Use**Item 419 - BOTO/MOTO Tire and Tube Repair or Replacement**

(419A) - Tire and Tube Repair

(419B) - Tire and Tube Replacement

1. When submitting bids, the TSP will submit a rate for each tire/tube repair/replacement.
2. Replacement tires must be equal to or greater than the ply rating of the tire being replaced.
3. If during the movement, the TSP has to repair/replace tires and/or tubes on the mobile home or boat, the TSP will invoice these charges,
 - 1) upon PPSO request, the TSP will be required to provide valid receipts signed by parties performing services including the serial numbers of the
 - a) new tires purchased, and
 - b) tires being replaced.
 - 2) replaced tires must be left with the mobile home or boat unless otherwise requested by the customer.

Item 420 - BOTO/MOTO Daily SIT Rate

1. SIT will be approved by the PPSO.
2. Storage charges apply for each day of storage and each time SIT service is rendered. The storage period will include the day the BOTO/MOTO is placed in storage, but not the day the BOTO/MOTO is removed from storage.

Item 421 - 497 - Reserved for Future Use**Item 498 - Explanation of Abbreviations and Reference Marks****CONUS Destination Rate Areas (Labeled Regions)**

Destination Rate Area (Region)	States
Region 1	Idaho, Oregon, Washington
Region 2	California, Nevada
Region 3	Arizona, New Mexico, Utah
Region 4	Montana, North Dakota, South Dakota, Wyoming
Region 5	Colorado, Kansas, Missouri, Nebraska
Region 6	Arkansas, Louisiana, Oklahoma, Texas
Region 7	Iowa, Michigan, Minnesota, Wisconsin
Region 8	Illinois, Indiana, Ohio
Region 9	Connecticut, Maine, Massachusetts, New Hampshire, New Jersey, New York, Pennsylvania, Rhode Island, Vermont
Region 10	Delaware, DC, Maryland, Virginia, West Virginia
Region 11	Alabama, Kentucky, Mississippi, Tennessee
Region 12	Georgia, North Carolina, South Carolina
Region 13	Florida
Region 14	Alaska (AK - domestic destination for some shipments)
Region 15	Intrastate
Region 16	Key West (Monroe County) US4965500

Origin Rate Area Abbreviations for U.S. States

Rate Area Name	Rate area code
Alaska (Zone) I	US8101000
Alaska (Zone) II	US8190100
Alaska (Zone) III	US8050500
Alaska (Zone) V	US8030400
Alabama	US47
Arizona	US79
Arkansas	US60
California-North	US87
California-South	US88
Colorado	US74
Connecticut	US16
Delaware	US22
District of Columbia	US24
Florida-North	US49
Florida-South	US4964400
Florida Keys	US4965500
Georgia	US45
Idaho	US83
Illinois	US38
Indiana	US36
Iowa	US53
Kansas	US58
Kentucky	US28
Louisiana	US64
Maine	US11
Maryland	US23
Massachusetts	US14
Michigan	US30
Minnesota	US50

Rate Area Name	Rate area code
Mississippi	US48
Missouri	US56
Montana	US70
Nebraska	US55
Nevada	US86
New Hampshire	US12
New Jersey	US19
New Mexico	US77
New York	US17
North Carolina	US40
North Dakota	US51
Ohio	US34
Oklahoma	US62
Oregon	US85
Pennsylvania	US20
Rhode Island	US15
South Carolina	US44
South Dakota	US52
Tennessee	US42
Texas-North	US66
Texas-South	US68
Utah	US76
Vermont	US13
Virginia	US25
Washington	US84
West Virginia	US27
Wisconsin	US32
Wyoming	US72

Item 499 - Surcharges

(499A) - Surcharges

- Bunker S/C (BSC)

- Port Congestion S/C (CON)

Surcharge: An extra fee, levied to a shipment, paid by the TSP, and sometimes reimbursed by the U.S. Government. COF and WAR must be included in the TSPs discounts.

1. Except for BSC and CON, surcharge reimbursement is considered on a case-by-case basis with reimbursement decision resting at the sole discretion of USTRANSCOM.
2. With the exception of fuel related surcharges and unless otherwise stated, all surcharges are meant to be temporary in nature and remain the same until the TSP has been provided official notification to incorporate such additional fees into their rate.
3. These services are billable when TSPs have actually paid for the service. Upon Government request, the TSP must provide a copy of paid receipt.
4. Specific surcharge definitions:
 - a. **Bunker Surcharge (BSC):** An extra charge, also known as Bunker Adjustment Factor (BAF) or Fuel Adjustment Factor (FAF), sometimes added to ocean TSP rates to offset for the additional cost of the ships' bunker fuel beyond the normal cost included in the ocean freight rate. This surcharge must be supported by an ocean bill from the actual Ocean Carrier documenting bunker as paid by TSP for fuel that powers the engine of a ship. This surcharge is applicable to COS 2 and D for Alaska waterhaul shipments only.
 - b. **Port Congestion Surcharge (CON):** An extra charge that is billed to the TSP for controlling the congestion of trucks/vessels entering/departing the port.
 - c. **Port/Terminal Security Handling Surcharge (COF):** An extra charge that is billed to the TSP for security of their cargo while at the port of embarkation/debarkation.
 - d. **War Risk Surcharge (WAR):** This item will rarely apply in the domestic market. Insurance coverage for loss of goods resulting from any act of war or as a result of the vessel "entering" the war risk area when billed by the ocean/air TSP.

Section 5: Volume Moves (VM)

Item 2000 - Purpose

1. Unless otherwise stated, all portions of this Tariff apply to VM.
2. This chapter provides the procedures and information required for TSPs to file voluntary individual rate tenders (IRTs) to transport DoD and USCG-sponsored VM to/from or within CONUS, Alaska, and DC.
3. These instructions supersede all previously published procedures, formats, and other information for IRT filings applicable to Domestic VM shipments.
4. Rates submitted for VM are the only time that two rates for a TSP will be permitted to be filed with USTRANSCOM from and to the same origin/destination and COS combination (i.e., one rate for the VM and another rate for regular channel).

Item 2001 - Criteria for Use of VM Rates

1. VM procedures will apply under the following conditions:
 - a. Estimated tonnage:
 - 1) consisting of HHGs totaling 200,000 lbs or more; however,
 - a) USTRANSCOM may request a VM for lesser tonnage to meet special operational requirements.
 - b) Although every effort is made to ensure personnel and tonnage estimates are accurate as possible, there is no guarantee on number of shipments or tonnage for any VM.
 - b. Movement is from one Origin City (within 75 miles or less radius) to one Destination City (within 75 miles or less radius).
 - c. Requests must be entered into DPS and submitted to USTRANSCOM at least 90 days prior to the requested start date of the VM. (Exceptions will be made on a case-by-case basis).
 - d. Movement is normally within a 90-day period; however, USTRANSCOM reserves the right to waive the normal 90-day period for VM, if circumstances warrant.
2. When circumstances warrant, USTRANSCOM can adjust the VM End Date by either shortening it or lengthening it. When lengthening the VM End Date, USTRANSCOM can extend up to 45 days to meet mission requirements.

Item 2002 - VM Procedures

1. When the above criteria for use exist, the responsible PPSO is required to submit a request via DPS to USTRANSCOM providing appropriate information. PPSOs must include
 - a. POC information (name, telephone number, and e-mail address),
 - b. any special operational requirements in the request, and

- c. The minimum amount of pounds to be handled by each bidding TSP, per day, is normally 40,000 lbs. USTRANSCOM reserves the right to adjust minimums to meet mission requirements.
2. USTRANSCOM will review the VM request and submit it for bids. DPS will send out an e-mail to all eligible TSPs with rates on file for the Channel-COS combination selected and who are eligible (not in a punitive status) to move HHGs throughout the VM (as of the VM Solicitation Date).
3. To participate in the VM,
 - a. TSPs must log into DPS, and
 - b. submit a rate that is lower (higher discounts for LH/SIT) than their rate on file for the same Channel-COS combination.
4. The deadline date for receipt of the rate tender number and bid information is specified in the VM Solicitation and can be viewed by logging into DPS.
5. TSPs are required to submit proper and complete information for bids to be considered responsive.

Item 2003 - Submission of Rates and Charges

1. The submission of voluntary bids into DPS is the only way to participate in the movement of DoD/USCG-sponsored VM. Rates and charges offered in bid submissions must be independently determined and expressed as indicated in Item 2003 (4) b.
2. Competitive rate tenders submitted in response to these filing procedures must be submitted by the exact deadline and under the exact terms, conditions, and procedures specified.
3. This solicitation stands alone, and is not influenced by prior practices or procedures, and is subject to modification by USTRANSCOM prior to the solicitation bid deadline or after as needed.
4. TSPs will submit their rates in DPS. For details on VM rate filing see the Volume Move User Guide Transportation Service Provider (TSP) Edition located in the Rates Module under the Volume Move section in DPS.
 - a. TSPs can enter only one bid per VM and rates must be error-free.
 - 1) The TSP may edit, change, correct, or delete any of their entered information during the bid window.
 - 2) After the VM Bid End Date/Time, no changes, withdrawals, or cancellations are allowed.
 - 3) DPS will prevent rates from being entered after the VM Bid End Date/Time.
 - 4) VM are not restricted by the Rate Cycle Dates, or Performance Periods.
 - b. The rate
 - 1) will be expressed as a discount off the Domestic 400NG Tariff. For example, if a TSP wishes to offer a 10% linehaul reduction, the rate submitted would be 10%. One percent will be shown to cover a reduction in total cost for linehaul and one percent for SIT.

- 2) VM shipments will operate the same as standard shipments except they will utilize the VM rates in place of the standard rates on file.
 - 3) The rates entered (either LH/SIT discounts) must be lower (higher discount for LH/SIT) than the bidding TSP's rate on file for the same Channel-COS combination.
 - 4) Each TSP's VM LH/SIT discounts will apply for each shipment shipped under the VM until its final delivery to the customer.
- c. In addition to rates and charges, the TSP must enter the following information to be eligible to participate in the VM:
- 1) The maximum amount of tonnage expressed in pounds per day that can be picked up. The TSP entered maximum amount cannot be below the minimum pounds established by USTRANSCOM.
 - 2) Tender Number.
 - 3) TSP POC information (name, telephone #, and e-mail address).
- d. The TSP must agree to the following information to be eligible to participate in the VM process:
- 1) Move at least the minimum pounds per day identified on the VM Solicitation.
 - 2) Move up to the maximum amount of pounds per day the TSP identified as being capable of handling.
 - 3) Not refuse any VM shipments. DPS will not offer shipments to a TSP that will exceed the TSPs maximum daily tonnage capability.
- e. USTRANSCOM will evaluate all competitive rate offers received from TSPs. Acceptance of rates does not guarantee any offer of shipments or tonnage (VM Solicitations are estimates).
- 1) Although no guarantee is expressed or implied, USTRANSCOM will make every effort to protect the confidentiality of rates submitted in response to a VM Solicitation.
 - 2) Domestic HHGs VM rates are processed by USTRANSCOM PP Special Requirements & Rates Team and any questions can be referred to them.

Item 2004 - Terms and Conditions for Individual Rate Bid Submission

TSPs that are in a suspended, non-use, disqualified, or other inactive status during any portion of the VM will not be considered. The rules and regulations contained in the VM procedures provide all terms and conditions and shall not be altered in any manner. These procedures will be retained by the participating TSP.

Item 2005 - Preparation of Individual Rate Submissions

Each TSP is completely responsible for the proper preparation and submission of its bid(s) in accordance with the procedures prescribed herein. E-mailed/faxed submissions will not be accepted.

Item 2006 - Effective Period for Accepted Bid Submission

The VM Bid Start Date and VM Bid End Date/Time will be identified in the initial e-mail sent to all eligible TSPs (see Item 2002) via DPS. USTRANSCOM reserves the right to adjust the VM Bid End Date/Time or re-solicit bids as determined necessary by USTRANSCOM.

Item 2007 - Receipt of Submission

1. All bid submissions must be received in DPS on or before the deadline date and time indicated on the solicitation, for each individual VM.
2. USTRANSCOM is not responsible for rates not in DPS prior to the deadline.
3. Computer glitches and other technology issues may occur when submitting bids, therefore TSPs should enter their bid into DPS as soon as possible to meet rate submission deadlines.
4. Bids will not be accepted after the VM Bid End Date/Time.
5. If TSPs have issues or discrepancies during the solicitation and bid process it is recommended they contact the USTRANSCOM System Response Center (DPS Helpdesk).

Item 2008 - Reserved for Future Use**Item 2009 - Punitive Action**

1. The provisions of this rate solicitation and the TOS apply equally whether moving HHGs lots individually or as a VM.
2. Any TSP who willingly submits a rate proposal that misrepresents a material fact shall be grounds for the disqualification of the TSP from future DoD/USCG personal property shipments.
3. TSPs are monitored by both the origin and destination JPPSO/PPSO Quality Assurance and subject to punitive actions outlined in DTR Part IV Chapter 405.
4. TSPs whose overall performance clearly indicates an unwillingness to comply with service standards shall be subject to punitive action. Whenever punitive actions are issued to a TSP, the resulting action (i.e., Letter of Warning, Letter of Suspension, or non-use) will apply to both regular and VM shipments. For questions or concerns, contact USTRANSCOM PP Quality Support Team.
5. VM shipment refusals are not authorized and may result in punitive action per DTR Part IV.
6. Failure to pickup VM shipments or comply with requirements may result in immediate suspension from the VM (to include shipments traveling over the same market not consigned to the VM). If repeated violations occur, suspensions may be progressively escalated as indicated in the DTR (4500.9-R).
7. All VM shipment CSSs are generated and counted towards the applicable market (domestic HHGs), and all existing CSS reports will include CSS data for VM shipments.

Item 2010 - Correction to VM Individual Rate

1. Corrections or changes to VM rates after the specified VM Bid End Date/Time will not be permitted.

2. The Chief of Operation Defense Personal Property Program, TCJ9 will not be responsible for late or misdirected rate bid submissions which do not arrive in DPS prior to the VM Bid End Date/Time when caused by any party or parties not assigned to USTRANSCOM.
3. USTRANSCOM reserves the right to reject any or all offers, waive informalities and minor irregularities in offers received, negotiate, or accept offers without discussion of rates, to nonuse any rate, "terminate", and/or re-solicit rates prior to or during the VM effective dates.

Item 2011 - Acceptance/Rejection of Individual Rate Submission

1. USTRANSCOM will review each rate submission prior to acceptance, rejection, or distribution. TSPs must use the utmost care in bid preparation since rates cannot be withdrawn after the bid end date and time expires.
2. DPS will notify each TSP via e-mail (to the TSP Master and TSP Operations user roles) with information relative to the acceptance or rejection of its tender.
 - a. Notification of Acceptance. Inquiries about this solicitation relative to TSP ranking and participation should be satisfied by reference to DPS and viewing the TSPs VM screens.
 - b. Notification of Rejection. Any TSP failing to enter a Tender Number, POC information, or other mandatory information will be stopped by DPS until the information is entered. Rejected TSPs will receive an e-mail indicating the basis for rejection. E-mail questions concerning rate filing to USTRANSCOM PP Special Requirement & Rates Team.

Item 2012 - VM Rates - Public File

All accepted Tender Numbers are kept via electronic means in DPS.

Item 2013 - Selecting Number One TSP for VM

Selection of number one TSP will be accomplished using the BVS computation matrix. TSPs can view their TSP's relative ranking (e.g., 2nd of 15) by logging into DPS.

Item 2014 - Reserved for Future Use

Item 2015 - Additional Guidance

1. When a TSP is offered and accepts a VM shipment and later negotiates a pickup date change outside the VM cycle, the shipment will move under the VM rate and tables that were effective on the original requested pickup date at the time the shipment was offered and accepted by the TSP.
2. DPS offers short-fused VM shipments to eligible VM TSPs on a first come, first serve basis. Short fuse awards will count towards minimum and maximum daily weight allocations. TSPs already reaching their maximum daily weight still receive short fuse shipment notifications and may accept the shipment if desired.
3. USTRANSCOM reserves the right to authorize manual submissions for VMs requests to support contingency plans in support of the DoD Personal Property mission. Authorized manual VMs will be managed on a case-by-case basis and all guidance will be communicated accordingly between the Origin JPPSO/PPSO and USTRANSCOM PP Special Requirements & Rates Team.
4. Under this Tariff PPSOs reserve the right to process shipments outside the VM using Standard Channel and current Rates on File to meet DoD mission requirements

Item 2016 - VM Shipment Distribution

1. DPS ranks VM TSPs from highest to lowest based on their BVS. The number one ranked TSP is displayed as the "Next TSP To Receive Shipment" and the next lower ranked TSP will be shown as the "Alternate TSP." VM TSPs who have met their maximum daily tonnage requirement will not be displayed and the next two sequentially ranked TSPs will appear as the "Next TSP To Receive Shipment" and "Alternate TSP." This process is system generated and the process repeats daily.
2. PPSOs shall distribute VM shipment tonnage as follows:
 - a. All VM shipments shall be offered to the number one ranked TSP until that TSP has reached the minimum daily tonnage.
 - b. Once the number one ranked TSP reaches the minimum daily tonnage, the PPSOs may award shipments to the alternate TSP.
 - c. When the number one ranked TSP has reached their maximum daily tonnage, the PPSO must distribute the shipment tonnage to the number two ranked TSP for the specified day until they reach the minimum daily tonnage (then repeat Item 2016 paragraph 2.b. above).

Item 2017 - 2022 - Reserved for Future Use**Item 2023 - VM Blackout Status**

1. VM Blackouts are identified by VM Start/End Dates, for a given VM or a set of VM.
 - a. TSPs will be provided the ability to blackout dates for all "Accepted" VM or select dates on a specific "Accepted" VM to blackout.
 - b. TSPs will not be allowed to blackout VM (s) before they are in an "Accepted" status.
2. TSPs in a VM Blackout status will be charged the "Administrative Tonnage" for any shipment they would have received had they not been blacked out.
3. TSPs not in VM Blackout status will be subject to punitive action if tonnage minimums are refused.
4. VM Blackouts are independent of any other blackout type in the system (e.g., a domestic HHGs blackout will not blackout a TSP for a VM under which they are accepted).

Appendix A: Costing a Domestic Shipment

Baseline Files and “How to”

1. This Appendix contains instructions for rating DoD shipments under the 400NG using the 400NG Baseline Rates Tariff file. To rate a shipment correctly, users need to know the weight, pickup date, and origin and destination ZIP codes of the shipment. The electronic rating engine uses the first three digits of the origin and destination ZIP codes to establish the corresponding Base Point City (BPC) at origin and destination. The rating engine then uses the shipment weight, pickup date, and mileage between the origin and destination BPC to compute baseline transportation linehaul cost. TSP Linehaul and SIT discounts apply to these baseline amounts. Charges apply on a seasonal basis; peak season charges apply on shipments picked up on May 15th through September 30th of each calendar year.
2. See <https://www.ustranscom.mil/dp3/pdfs.cfm> for the "(appropriate Rate Cycle) 400NG Baseline Rates Tariff" file as well as the supplemental "400NG Rating Tool". The 400NG Baseline Rates Tariff provides baseline dollar amounts and accessorial charges, which should be reduced by linehaul or SIT discounts as needed. The "400NG Rating Tool" supplements this Appendix by providing users 400NG mileage (including waterhaul mileage) and guidelines for rating 400NG shipments. The 400NG, 400NG Rating Tool are located at the link and site path above. When rating a shipment under 400NG, it is important to note the following:
 - a. The U.S. (except Hawaii) is divided into three-digit ZIP Codes (ZIP3).
 - b. Each ZIP3 is assigned to a BPC.
 - c. Each BPC is assigned to a Service Area (SA).
3. Mileages are based on MG 19 and are from BPC to BPC unless a shipment picks up and delivers within the same ZIP3. In those cases, DTOD mileage will apply and users must enter DTOD miles into the "400NG Rating Tool." DTOD miles can be obtained in DTOD at <https://dps.move.mil/cust/standard/user/home.xhtml>

A. General Information

1. All charges within this document are divided into LHS and non-LHS.
2. Only the first three positions of a ZIP code are needed for shipment rating purposes.
3. Following is a list of the information needed before a shipment can be rated as well as a symbol for each item:

Acronym	Description
BLHS	Base Linehaul
CWT	Hundred Weight (TWT / 100)
CWT-M	Hundred Weight Miles
dLHS	LH Discount
dSIT	SIT Discount
DZIP3	ZIP code at Destination - first three positions
Intra-AK	Intra-Alaska Miles
InvdLHS	HHGs % of Tariff (inverse of dLHS)
InvdSIT	SIT % of Tariff (inverse of dSIT)

Acronym	Description
LBLHS	Lower 48 Base Linehaul
LHS	Linehaul Charge
OLF/DLF	Linehaul Factor (Origin and Destination)
OZIP3	ZIP code at Origin - first three positions
P/D	Pickup/Delivery
SH	Shorthaul
TWT	Total Weight
WHC	Waterhaul Charge

4. To obtain a discounted rate, multiply the baseline amount by the inverse of dLHS. The inverse of the discount (InvdLHS or InvdSIT) is 1.00 minus the discount (dLHS or dSIT) where the discount is expressed as a fraction (e.g., 71% discount is 0.71).

$$\text{InvdLHS} = 1.00 - \text{dLHS}$$

$$\text{InvdSIT} = 1.00 - \text{dSIT}$$

For example, the inverse LHS discount for a 55% LHS discount would be: $\text{InvdLHS} = (1.00 - 0.55) = 0.45$

5. Linehaul and SIT discounts can be retrieved from the TSP's invoice for BL shipments or in DPS Analytics.

B. Linehaul Charges

- LHS are the charges associated with the loading, transporting, and unloading of the shipment. The LHS may have up to three components:
 - BLHS
 - OLF/DLF
 - SH (may not apply)
- BLHS is the charge element for the transportation of the shipment from origin (block 19) to destination (block 18), through any stops along the way. BLHS is computed using the total weight and total miles of the shipment.
- OLF and DLF are an additional linehaul component that accounts for varying transportation costs associated with each SA.
- SH is an additional linehaul component for shipments moving 800 miles or less on all modes combined. SH is based on a new unit of measure called hundred weight miles (CWT-M). Determine CWT-M by multiplying total shipment miles by the cwt. Find Item 999 in the baseline tariff files and apply the correct sub-item rate on the CWT-M.

5. In order to determine if a shipment is eligible for an SH charge, PPSOs must factor in all transportation segment miles. If SH is paid and a shipment moves greater than 800 miles, the TSP MUST reimburse the total SH amount paid via EDI.
6. Use the following information as our EXAMPLE for shipments in the lower 48 states:

Origin ZIP3 (OZIP3): 395
Origin BPC: Saucier, MS
Origin SA Number: 428
Origin SA Name: Gulfport, MS
Est. Weight: 6,000
Miles: 565
Crate: 4.3 cu ft.

Destination ZIP3 (DZIP3): 336
Destination BPC: Tampa, FL
Destination SA Number: 197
Destination SA Name: Tampa FL Metro
Pickup Date: 05/16/2017
Discounts: dLHS = 57%; dSIT = 55%
SIT days (total): 16 days

7. The 400NG Rating Tool will perform the steps below; however, users can manually look up this information using the following steps:
 - a. Using the OZIP3 and DZIP3, go to the “Base Point City” tab in the baseline tariff file under Column E and locate the ZIP3s for the shipment origin and destination. Record the SA, under Column D, that corresponds to each ZIP3.
 - b. Go to the “Geographical Schedule” tab in the file and locate your “Service Area Number/Name” (Column A) to show applicable charges.

Computing Linehaul Charges (LHS)

The guidance below will help compute/validate 400NG HHGs Domestic LHS:

Formula: $LHS = [BLHS + OLF + DLF + SH] \times \text{InvdLHS}$.

1. Unless otherwise mentioned, all reference to “tabs” in this document refers to worksheets located inside the “400NG Baseline Rates” tariff file located at <https://www.ustranscom.mil/dp3/pdfs.cfm> <https://www.ustranscom.mil/dp3/pdfs.cfm> (Under Household Goods section).
2. SH is only applicable if total mileage from requested pickup address (block 19 on the BL) to the requested delivery addresses (block 18 on the BL) at the time the shipment is offered to and accepted by the TSP is 800 miles or less.

Determine the Base Linehaul (BLHS)

1. Using the “400NG Rating Tool,” enter the Origin and Destination ZIP3 and the tool will provide the 400NG mileage from origin BPC to destination BPC (our example is 565 miles).
2. Using this 400NG mileage, go to “400NG Linehaul Rates” tab, lookup the Linehaul table. Using the mileage and shipment weight, locate the baseline amount in the table (our example is \$6,845).

Note: Baseline amounts in 400NG are in dollars (\$) and NOT \$/cwt.

Determine the Origin and Destination Linehaul Factors (OLF/DLF)

3. Using the “400NG Rating Tool,” enter the Origin and Destination ZIP3 and the tool will provide the SA that apply (origin 428 and destination 197).

To manually calculate: Using the OZIP3 and DZIP3, go to 400NG Baseline Rates file “Base Point City” tab and lookup the row that contains each ZIP3 (first 3 numbers of ZIP code). Get the SA that applies to each ZIP3 (origin 428 and destination 197).

4. Go to “Geographical Schedule” tab and find the row for each SA.
 - a. This gives you the applicable linehaul factor for OLF and DLF, both are needed to compute the LHS (our example is OLF - \$0.57 per cwt and DLF - \$0.69 per cwt).
 - b. Using these numbers, compute the OLF (our example is $\$0.57 \times 60$ (cwt of shipment) = \$34.20). Now do the same for the DLF (our example is $\$0.69 \times 60$ cwt = \$41.40).

Determine SH Charge (ONLY applies if shipment moves 800 miles and less)

1. Multiply the cwt by the mileage (our example is $60 \text{ cwt} \times 565 \text{ miles} = 33,900 \text{ CWT-M}$).
2. Go to 400NG Baseline Rates “Additional Rates” tab and use the total above to find which SH bracket (Item Number 999) and locate the amount (our example is \$250.17).

Determine Linehaul Charge (LHS) TOTAL

1. Add the BLHS total (our example is \$6,845), the OLF (our example is \$34.20), the DLF (\$41.40), and the SH (\$250.17) and multiply this by the InvdLHS (our example is .43).
2. Total LHS Calculations: $(\$6,845 + \$34.20 + \$41.40 + \$250.17) \times .43 = \$3,083.43$ (use conventional rounding if applicable to 2 decimal points).

Computing Non-Linehaul Charge

Item 135A (Origin Service Fee)

Formula: $135A = (135A \text{ rate} \times \text{cwt of shipment}) \times \text{InvdLHS}$.

1. Using the OZIP3 go to 400NG Baseline Rates “Base Point City” tab and find the SA that applies to the ZIP3.
2. Go to “Geographical Schedule” tab, find your SA, and locate the 135A rate (our example is \$3.50).
3. Using this number, compute the charge using 135A rate X cwt of shipment, then multiply that by the InvdLHS (our example is $(\$3.50 \times 60) \times .43 = \90.30).

Item 135B (Destinations Service Fee)

Formula: $135B = (135B \text{ rate} \times \text{cwt of shipment}) \times \text{InvdLHS}$.

1. Using the DZIP3, go to 400NG Baseline Rates “Base Point City” tab and find the SA that applies to the ZIP3.
2. Go to “Geographical Schedule” tab, find your SA, and locate the 135B rate (our example is \$6.63).
3. Using this number, compute the charge multiplying the 135B rate with the cwt of shipment, then multiply that by the InvdLHS (our example is $(\$6.63 \times 60) \times .43 = \171.05).

Item 105A (Full Pack/Unpack)

Formula: Pack = (Pack rate X cwt) X InvdLHS
 Unpack = (Unpack rate X cwt) X InvdLHS

Note: Before figuring packing/unpacking charges, get the Service Schedule (1, 2, 3, or 4) that applies to your SA from the “Geographical Schedule” tab for both origin and destination. Once you have these, go to the “Additional Rates” tab.

1. Determine Pack:
 - a. Look up the rate for Full packing for your origin schedule and weight bracket (there are 4 SAs make sure you use the one that goes with your Service Schedule) (our example is \$54.29).
 - b. Multiply this number by the cwt then multiply the total by the InvdLHS (our example is $\$54.29 \times 60 \times .43 = \$1,400.68$).
2. Determine Unpack:
 - a. Look up the rate for Full Unpack for your destination schedule and weight bracket (there are 4 SAs make sure you use the one that goes with your destination Service Schedule). There is only one unpack charge per Service Schedule regardless of weight (our example is \$5.70045).
 - b. Multiply total by the cwt and then by the InvdLHS (our example is $\$5.70045 \times 60 \times .43 = \147.07).

Item 105B (Crating) and (Uncrating) Regular Crate

Formula: Crating = (Crating rate (for schedule) x cu ft.) x InvdLHS

Note: Crating is charged by cu ft., or fraction thereof, and is subject to 4 cu ft. minimum. Crating is based on the rate per cu ft. at the origin schedule.

Determine Crating (105B)

1. Crating - In the “Additional Rates” tab, look up the rate for Item Code 105B for your origin Schedule (there are 4 SAs, but the cost is the same for all 4 SAs) (our example is \$22.75/cu ft.).
 - a. Multiply each number by the cu ft. of the crate and then by the InvdLHS (our example is $\$22.75 \times 4.3 \times .43 = \42.06).

Item 185A (First Day) and Item 185B (Additional Days) SIT

Formula: 185A = (1st Day SIT Charge X cwt) X InvdSIT
 185B = (SIT Additional Day X cwt X Days) X InvdSIT

2. To calculate SIT charges, go to the “Geographical Schedule” tab and follow your SA number across to get your Item 185A (SIT 1st day) rate and 185B (SIT additional days) rate for origin and/or destination. BL, block 19 (pickup) and block 18 (delivery) ZIP3 are required to validate SIT charges. SIT charges are NOT determined by the SIT facility ZIP3 (see Item 185 of the 400NG Tariff).
 - a. Determine SIT First Day (185A)
 - 1) 1st Day SIT - use the “185A SIT First Day & Warehouse (per cwt)” rate for the OZIP3/DZIP3 (where shipment is in SIT). Multiply this number (our example is \$14.36/cwt) by the cwt (our example is $\$14.36/\text{cwt} \times 60 \text{ cwt} = \861.60).
 - 2) Multiply total by the InvdSIT discount (our example is $\$861.60 \times .45 = \387.72).

b. Determine SIT Additional Days (185E)

- 1) Additional SIT Days - using the "185B SIT Additional Day" on the "Additional Rates" tab for the OZIP3/DZIP3 (where shipment is in SIT).
- 2) Multiply this number (our example is \$.50) by the cwt (our example is $.50 \times 60 = \$30.00$). Multiply total by the number of additional SIT days, then multiply the total by the InvdSIT (our example is $(\$30.00 \times 15) \times .45 = \202.50).

Item 210A (SIT Pickup/Delivery 30 Miles or Less), Item 210B (SIT Pickup/Delivery 31-50 Miles), Item 210C (SIT Pickup/Delivery Over 50 Miles), and Partial Deliveries out of SIT (less than 1,000 lbs):

Formula: $210A = 210A \text{ table charge} \times \text{InvdSIT}$

$210B = (210A \text{ table charge} + 210B \text{ charge}) \times \text{InvdSIT}$

1. Use "SIT Pickup/Delivery (P/D)" Schedule (1, 2, 3, and 4) that corresponds to your origin/destination SA which can be found on the "Geographical Schedule" tab. You need the BL - block 19 (origin SIT) and block 18 (destination SIT) ZIP3s, weight delivered into or out of SIT, and the mileage between block 18 of BL and the actual delivery address to validate SIT charges. SIT charges are NOT determined by the SIT facility ZIP3 (see Item 185 of the 400NG Tariff).
 - a. Determine 210A (SIT Pickup/Delivery 30 Miles or Less)
 - 1) Go to "Accessorial" tab, locate intersection of the appropriate "SIT P/D Schedule" (this needs to be looked up in the "Geographical Schedule" tab) and miles (our example for destination P/D SIT is \$2,258).
 - 2) Multiply total by InvdSIT (our example is $\$2,258 \times .45 = \$1,016.10$).
 - b. Determine 210B (SIT Pickup/Delivery 31-50 Miles)
 - 1) Compute Item 210A first using guidance above.
 - 2) Go to "Additional Rates" tab and get "SIT Pickup/Delivery 31 - 50 miles" for the "SIT P/D" Schedule that applies to your location (our example is \$136.59).
 - 3) Multiply total by InvdSIT (our example is $\$136.59 \times .45 = \58.73).
 - 4) Add 210B charge and 210A charge (our example is $\$58.73 + \$1,016.10 = \$1,074.83$).
2. Exclusions apply such as changes prior to pickup and diversions. References made to blocks in the BL will be reflected in the DPS BL at the completion of the pre-move survey.
3. Determine Partial Deliveries out of SIT based on actual weight / less than a 1,000 lbs
 - a. Compute the delivery out of SIT based on the SA rate for a minimum of a 1,000 lbs using guidance above. For our example partial delivery out of SIT weight is 260 lbs.
 - b. Multiply this cost by the applicable Invd discount (our example is $\$565 \times .45 = \254.25).
 - c. Multiply the result above by the actual weight using the fraction system (of a 1,000 lbs) (our example is $\$254.25 \times .260 = \66.11).

How to Calculate Shipment To/From Alaska

Alaska BPCs are not the same as the Lower 48 BPCs, some Alaska BPCs have more than one ZIP3 assigned (see listing below), and some ZIP3s apply to multiple BPCs. Use the Alaskan BPC (with the same Associated ZIP3) nearest to block 18/19 of the BL to determine which Alaskan BPC to use. When only one BPC (with the Associated ZIP3) is on the same land mass, that BPC must be utilized.

Alaska Base Point Cities	Associated ZIP3s
Sitka	998
Ketchikan/ Juneau	999 998
Anchorage	995, 996
Petersburg/ Wrangell	998, 999 998, 999
Kodiak	995, 996
Cordova Fairbanks	997 997

4. We used the following information as our EXAMPLE for a domestic shipment to/from Alaska:

Origin ZIP3 (OZIP3): 631	Destination ZIP3 (DZIP3): 997
Origin BPC: St Louis, MO (Metro)	Destination BPC: Fairbanks, AK
Origin SA Number: 457	Destination SA Number: 22
Origin SA Name: St Louis, MO (Metro)	Destination SA Name: Alaska, All Points
Est. Weight: 7,500	Pickup Date: 12 June 2017
Miles: 2,078 (by water)	dLHS = 57%, dSIT = 55%
Intra-Alaska Miles: 45 (from BPC to block 18/19 of BL)	SIT days (total): 16 days
Crate: 4.33 cu ft. (Dimensions = 22" X 20" X 17")	Lower 48 Water Port: Tacoma

Shipments To/From Alaska

Formula: $LHS = [LBLHS + OLF + DLF + WC + \text{Intra-AK BLHS}] \times \text{InvdLHS}$

1. Determine BLHS Charges and LBLHS Mileage Cost Factor
 - a. Using the "400NG Rating Tool," enter the OZIP3, DZIP3, and AK Destination (Fairbanks) and the tool will provide the 400NG mileage from origin BPC to destination BPC (our example is 2,078 miles).
 - b. Using the 400NG mileage, go to "400NG Baseline Rates," go to "Linehaul" tab and find "Section 3 - Linehaul." Using the mileage and shipment weight, locate the baseline amount in the table. (Our example is \$14,008).
2. Determine Intra-AK LHS (Only applicable if the mileage is over 14 miles from the AK BPC and block 18/19 of the BL).

- a. Using the mileage from the BPC and block 18/19 of BL, go to the "Linehaul" Spreadsheet and find "Section 7 - Intra-AK." (Our example is 45 miles and the cost is \$3,381).
3. Determine the WHC Factor
 - a. Go to "400NG Baseline Rates" and open up "Accessorial" tab. Go to "Section 6: AK Waterhaul", using the AK water port and the weight, lookup the charge. (Our example is Fairbanks and cost is \$12,970).
4. Determine the OLF/DLF
 - a. Using the OZIP3 and DZIP3, go to "400NG Baseline Rates" file "Base Point City" tab and lookup the row that contains each ZIP3. Get the SA that applies to each ZIP3 (origin 631 and destination 997). Our SAs are: origin 457 and destination 22.
 - b. Go to "Geographical Schedule" tab and find the row for each SA. This gives you the applicable linehaul factor for OLF and DLF, both are needed to compute the LC (our example is OLF - \$1.07/cwt and DLF - \$5.32/cwt).
 - c. Using these numbers, compute the OLF by multiplying the total by the cwt (our example is $\$1.07 \times 75 = \80.25). Do the same for the DLF (our example is $\$5.32 \times 75 = \399.00).
5. Determine Linehaul Charge (LC) Total
 - a. Add the BLH total, the OLF, the DLF and the WHC, then multiply this by the InvdLH (our example is $(\$14,008 + \$3,381 + \$12,970 + \$80.25 + \$399.00) \times .43 = \$13,260.45$ (use conventional rounding if applicable to 2 decimal points).

Computing Non-Linehaul Charge

Item 135A (Origin Service Charge)

Formula: $135A = (135A \text{ rate} \times \text{cwt of shipment}) \times \text{InvdLHS}$

1. Determine 135A (Origin Service Charge)
 - a. Using the OZIP3 go to 400NG Baseline Rates "Base Point City" tab and find the SA that applies to the ZIP3.
 - b. Using "Geographical Schedule" tab, find your SA and locate the 135A rate (our example is \$7.99).
 - c. Compute the charge by multiplying the 135A rate and the cwt of shipment then multiply that by the InvdLHS (our example is $\$7.99 \times 75 \times .43 = \257.68).

Item 135B (Destination Service Charge)

Formula: $135B = (135B \text{ rate} \times \text{cwt of shipment}) \times \text{InvdLHS}$

1. Determine 135A (Destination Service Charge)
 - a. Using the DZIP3, go to 400NG Baseline Rates "Base Point City" tab and find the SA that applies to the ZIP3.
 - b. Go to "Geographical Schedule" tab, find your SA, and locate the 135B rate (our example is \$7.01).

- c. Using this number, compute the charge multiplying the 135B rate and the cwt of shipment, then multiplying the total by the InvdLHS (our example is $\$7.01 \times 75 \times .43 = \226.07).

Item 105A (Full Pack/Unpack)

Formula: Full Pack = (Full Pack rate X cwt) X InvdLHS
 Full Unpack = (Full Unpack rate X cwt) X InvdLHS

Note: Before figuring packing/unpacking charges, get the Service Schedule (1, 2, 3, or 4) that applies to your SA from the “Geographical Schedule” tab for both origin and destination. Once you have these, go to the “Additional Rates” tab.

1. Determine 105A (Full Pack)
 - a. Look up the rate for Full packing for your origin Schedule and weight bracket (there are 4 SAs, make sure you use the one that goes with your Service Schedule) (our example is \$60.05).
 - b. Multiply total by the cwt and then by the InvdLHS (our example is $\$60.05 \times 75 \times .43 = \$1,936.61$).
2. Determine 105A (Full Unpack)
 - a. Look up the rate for Full Unpack for your destination Schedule (there are 4 SAs make sure you use the one that goes with your destination Service Schedule).
 - b. There is only one unpack charge per Service Schedule regardless of weight (our example is \$7.5054).
 - c. Multiply total by the cwt and then by the InvdLHS (our example is $\$7.5054 \times 75 \times .43 = \242.05).

Item 105B (Pack Regular Crate) and (Unpack Regular Crate)

Formula: Crating = (Crating rate (per schedule) x cu ft.) x InvdLHS

Crating is charged by cu ft., or fraction thereof, and is subject to a 4 cu. ft. minimum.
 Crating is based using the origin schedule.

1. Determine 105B (Pack Regular Crate)
 - a. In the “Additional Rates” tab, look up the rate for Item Code 105B for your origin Schedule. There are four SAs, but the cost is the same for all four SAs (our example is \$22.75/cu ft.).
 - b. Multiply the rate by the cu ft. and then multiply that total by the InvdLHS (our example is $(\$22.75 \times 4.33) \times .43 = \42.36).

Item 185A (SIT 1st Day) and Item 185B (SIT Additional Day)

Formula: 185A = (1st Day SIT Charge X cwt) X InvdSIT
 185B = (SIT Additional Day X cwt X Days) X InvdSIT

1. You need the BL block 19 (pickup) and block 18 (delivery) ZIP3 to validate SIT charges. SIT charges are NOT determined by the SIT facility ZIP3 (see Item 185 of the 400NG Tariff).
2. Determine 185A (1st Day SIT)

- a. Go to the “Geographical Schedule” tab and follow your SA number across to get your 185A rate using the 185A SIT First Day & Warehouse (per cwt)” rate (our example is \$13.66/cwt) (for our example we used destination SIT).
 - b. Multiply this number by the cwt and then multiply that total by the InvdSIT (our example is $(\$13.66 \times 75) \times .45 = \461.03).
3. Determine 185B (SIT Additional Day)
- a. Go to the “Geographical Schedule” tab and follow your SA number across to get your 185B rate using the 185B SIT Additional Day (per cwt)” Rate (our example is \$.50/cwt) (for our example we used destination SIT)
 - b. Multiply this number by the cwt and then multiply that total by the total number of days minus 1 (our example is $16 - 1 = 15$) and then multiply that total by the InvdSIT (our example is $[(\$0.50 \times 75) \times 15] \times .45 = \253.13).

Item 210A (SIT Pickup/Delivery 30 Miles or Less), Item 210B (SIT Pickup/Delivery 31-50 Miles), and 210F (SIT Pickup/Delivery Over 50 Miles (Alaska))

Formula: $210A = 210A \text{ table charge} \times \text{InvdSIT}$
 $210B = (210A \text{ table charge} + 210B \text{ charge}) \times \text{InvdSIT}$

1. Use “SIT P/D” Schedule (1, 2, 3, and 4) that corresponds to your origin/destination SA which can be looked up under the “Geographical Schedule” tab. You need the BL, block 19 (origin SIT) and block 18 (destination SIT) ZIP3, the weight delivered into or out of SIT, and the mileage between block 18 of BL and the actual delivery address to validate SIT charges. SIT charges are NOT determined by the SIT facility ZIP3 (see Item 185 of the 400NG Tariff).
2. Determine 210A (SIT Pickup/Delivery 30 Miles or Less)
 - a. Go to “Accessorial” tab, locate intersection of the appropriate “SIT P/D Schedule” (this needs to be looked up in the “Geographical Schedule” tab) and miles (our example for destination P/D SIT is \$3,887).
 - b. Multiply total by InvdSIT (our example is $\$3,887 \times .45 = \$1,749.15$).
3. Determine 210B (SIT Pickup/Delivery 31-50 Miles)
 - a. Compute Item 210A first using guidance above.
 - b. Go to “Additional Rates” tab and get “SIT Pickup/Delivery 31 - 50 miles” for the “SIT P/D Schedule” that applies to your location (our example is \$161.68).
 - c. Multiply total by InvdSIT (our example is $\$161.68 \times .45 = \72.76).
 - d. Add 210B charge and 210A charge (our example is $\$72.76 + \$1,749.15 = \$1,821.91$).
 - e. Exclusions apply such as changes prior to pick up and diversions. References made to blocks in the BL will be reflected in the DPS BL at the completion of the pre-move survey.

Bunker Surcharge

Formula: $\text{Individual Shipment Net Weight} \div \text{Total Container Weight} \times \text{Total Container BSC}$
 (sometimes listed as FSC) = Individual shipment BSC.

1. Example: Individual shipment net weight = 3,000 lbs, total container (SEAVAN) net weight = 10,273 lbs, BSC is \$697.90.
 - a. Divide the individual shipment net weight by the total container net weight per ocean carrier invoice ($3,000 \div 10,273 = .2920$ or 29.20% (do not round)).
 - b. Multiply the total container BSC by the percentage received from the computation above ($\$697.90 \times .2920 = \203.79).
 - c. Your BSC for the shipment = \$203.79.

CERTIFICATION OF INDEPENDENT PRICING

Please review and agree to the following terms and conditions:

1. For the purpose of inducing the United States to accept these tendered rates of fares, the undersigned declares, with the understanding that a false statement is a violation of law subject to criminal and civil penalties, that the following is true:
 - a) Except as described in paragraph 2, below, the rates or fares in tenders submitted in response to United States Transportation Command (USTRANSCOM) rate solicitations have been arrived at independently and, there has been no communication, agreement, understanding, collusion, or any other action in respect to these rates or fares, with any carrier, competitor, or agent thereof.
 - b) Except as described in paragraph 2 below, the rates or fares or other related information submitted have not and will not be disclosed directly or indirectly to any other carrier, competitor, or agent thereof prior to public disclosure of such rates by a government agency with which they have been filed.
 - c) No action has been or will be taken, and no agreement or understanding has been made or will be made, with any other carrier, competitor, or agent thereof to:
 - (1) submit or not to submit rates or fares; or
 - (2) change, cancel, or withdraw rates or fares; or
 - (3) file the same or prearranged rates or fares; or
 - (4) restrict competition for United States Government traffic by any means or device.
2. It is understood that this certification does not prohibit discussions concerning this tender between a freight forwarder and its underlying carriers, between a carrier or freight forwarder and its agents providing underlying transportation service or equipment, or between or among interline carriers jointly participating in rate tenders. It is also understood that this certification does not prohibit discussions concerning these tenders between commonly owned companies (carriers or freight forwarders) if the common ownership has been previously disclosed in writing to the USTRANSCOM. Further, this certification does not prohibit discussions concerning rate tenders between a carrier and its rate filing agents or consultants, provided that the carrier has instructed in writing such agents or consultants to preserve the confidentiality of such discussions.
3. The undersigned further certifies that I am responsible for determining the rates or fares being offered in rate tenders: that I have been authorized, in writing, to sign this certificate on behalf of the carrier; that I have not participated and will not participate in any action contrary to subparagraphs 1. a) through 1. c) above; and, that I have no knowledge that any other person has taken such action: OR
 - a) I am an authorized agent for the carrier; that I have not personally participated, and will not participate, in any action contrary to subparagraphs 1. a) through 1. c) above; that as an agent I have been authorized, in writing, to certify, and do hereby certify that the following principals have not participated in any action contrary to subparagraphs 1. a) through 1. c) above:
 - b) This certification applies to any medium used for the offering of the rates or fares, to include paper and any type of electronic submission.

Transportation Service Provider Name

SCAC

Printed TSP President/CEO Name

Signature of TSP President/CEO

Date

Figure 1. Certification of Independent Pricing

NONDISCLOSURE AGREEMENT FOR USTRANSCOM DP3 PROGRAM

This Agreement is a standard agreement designed for use by any Transportation Service Provider (TSP) or TSP Representative who is filing rates to be utilized in the United States Transportation Command (USTRANSCOM) Defense Personal Property Program (DP3). Its use is designed to protect non-public information from disclosure, identify potential conflicts of interest, and prevent violations of federal statutes or regulations. The restrictions contained in this agreement also serve TSPs by promoting compliant behavior that keeps TSPs eligible to compete in DP3 and compliant with Federal anti-trust laws. In addition to the potential impact on future business opportunities, failure to abide by this agreement could result in administrative, civil, or criminal penalties specified by statute or regulation.

1. I, _____ currently an employee of _____, hereby agree to the terms and conditions set forth below.
2. I understand that I may have access to confidential business information, TSP bid or proposal information (as defined by FAR 3.104-1), source selection information (as defined by AR 2.101), TSP rates, and discounts through use of the DP3. I fully understand that such information is sensitive and must be protected in accordance with 41 US Code Section 423 and FAR SubPart 3.1.
3. In the course of shipping under DP3 contract or some other contract or sub-contract for USTRANSCOM, I agree to:
 - a) Use only for Government purpose any and all confidential business information, TSP bid or proposal information, TSP rates and discounts to which I am given access. I agree not to disclose "non-public information" by any means (in whole or in part, alone or in combination with other information, directly, indirectly, or derivatively) to any person except to a US Government official or system with a need to know or to a non-Government person (including, but not limited to, a person in my company, affiliated companies, sub-contractors, etc.) who has a need to know related to the immediate contract/order, has executed a valid form of this non-disclosure agreement, and receives prior clearance by USTRANSCOM. All distribution of the agreement/documents will be controlled with the concurrence of USTRANSCOM.
 - b) "Non-public information," as used herein includes trade secrets; confidential or proprietary business information (as defined for Government employees in 18 USC 1905); bidding information (future bids, acquisition or bidding strategies, TSP bids or proposal information); sensitive information protected from release under the Freedom of Information Act (privileged material, etc.); and information that has not been released to the general public and has not been authorized for such release (as defined for Government employees in 5 CFR 2635.703).
 - c) Not use such information for any non-Governmental purposes, including, but not limited to, the preparation of bids or proposals, or the development or execution of other business or commercial ventures.
 - d) Store the information in such a manner as to prevent inadvertent disclosure or releases to individuals who have not been authorized access to it.
4. I understand that I must never make an unauthorized disclosure or use of confidential business information, TSP bid or proposal information, sensitive information on TSP rates or discounts unless:
 - a) USTRANSCOM determines that such information is not subject to protection from release.

Figure 2. Nondisclosure Agreement

5. I agree that I shall not seek access to “non-public information” beyond what is required for the performance of the services I am contracted to perform. I agree that when I seek access to such information, attend meetings, or communicate with other parties about such information, I will identify myself as a contractor performing rate filing services. Should I become aware of any improper or unintentional release or disclosure of “non-public information,” I will immediately report it to USTRANSCOM in writing. I agree that I will return all forms (including copies or reproduction of original documents) of any “non-public information” provided to me by the Government for use in performing my duties to the control of the Government when my duties no longer require this information.
6. Because the Government expects compliance with all statues and regulations from contractors performing work in DP3, I agree to advise USTRANSCOM of any actual or potential personal conflicts of interest I may have related to any work I perform in DP3 in representing a TSP to the government.
7. **Personal conflicts of interest include:**
 - a) Any matter in which I or my spouse, minor child, or household member has a financial interest.
 - b) **A financial interest:** Is any interest in, or affiliation with, a prime contractor, subcontractor to a prime contractor, any offeror(s), or any prospective subcontractor to any offeror for the program, contract, or other matter for which I am performing a support task under this contract.
 - c) The financial interest can take the form of any ownership interest (including but not limited to: stock; ownership of bonds; vested or unvested retirement benefits; a loan or other financial arrangement that is other than an arm’s-length transaction; employment, or an arrangement concerning prospective employment including negotiations therefore; or any non-arm’s length loan, any gift from or other non-arm’s length financial arrangement with any person who is directly communicating with the government on behalf of the prime contractor, subcontractor, or any prospective subcontractor or offeror).
 - d) **With respect to conflict of interest:** If any potential conflicts of interest, real or otherwise, do present themselves, then I shall immediately disclose the pertinent information to USTRANSCOM.

By signing below, I certify that I have read and understand the terms of this Non-Disclosure Agreement and Agreement to Disclose Potential Conflicts of Interest, and voluntarily agree to be bound by its terms.

Transportation Service Provider Name

SCAC

Printed TSP President/CEO Name

Signature of TSP President/CEO

Date

Printed Automated Data Processing (ADP)
Agent/Rate Filing Representative Name

Signature of Printed ADP Agent/Rate
Filing Representative

Date

Figure 2. Nondisclosure Agreement (Cont'd)

Figure 3. DP3 Regions Map

DP3 Regions

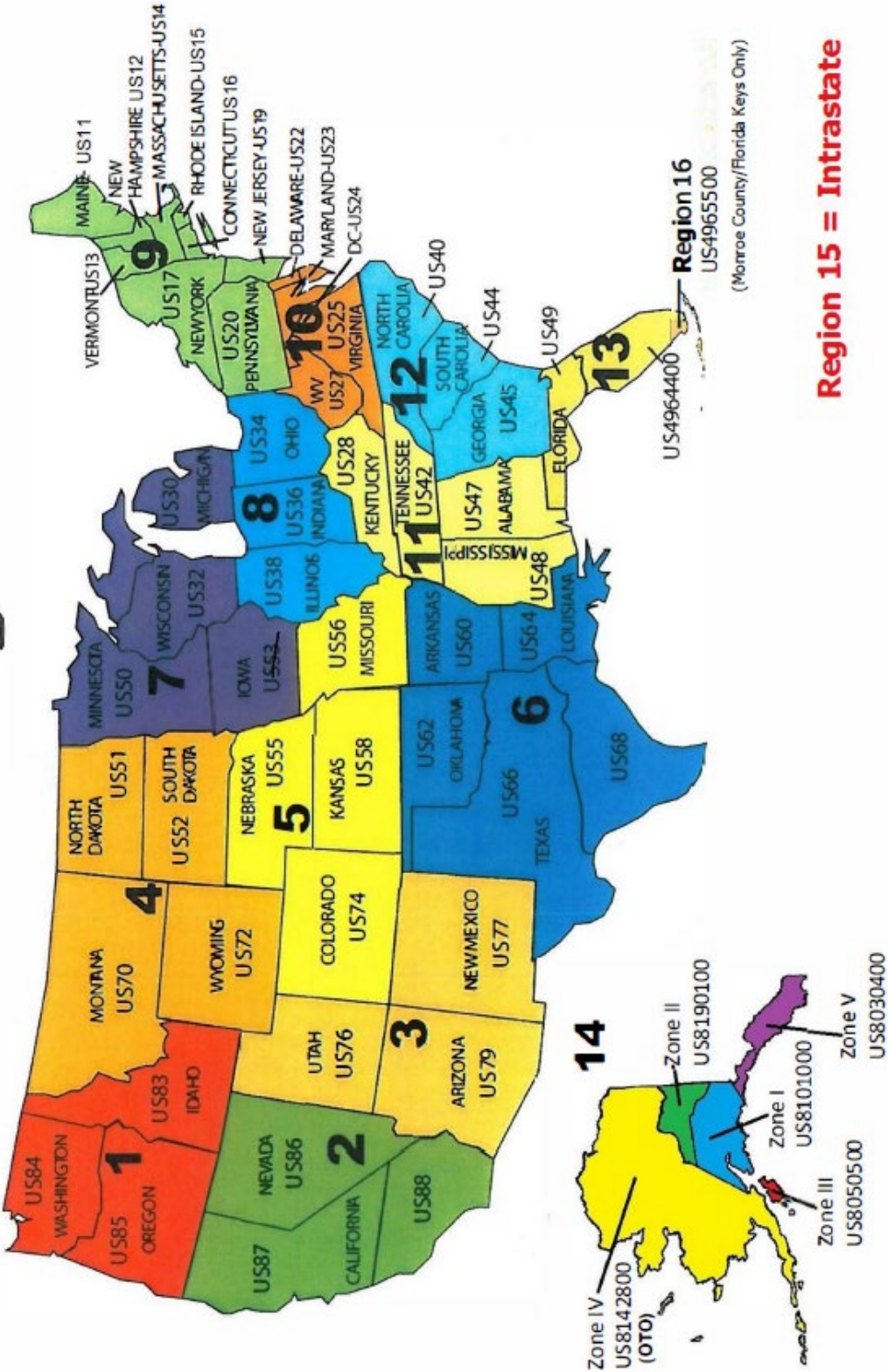

Region 15 = Intrastate